

Sumitomo Drive Technologies
Always on the Move

PREST[®] NEO

0.1kW~2.2kW

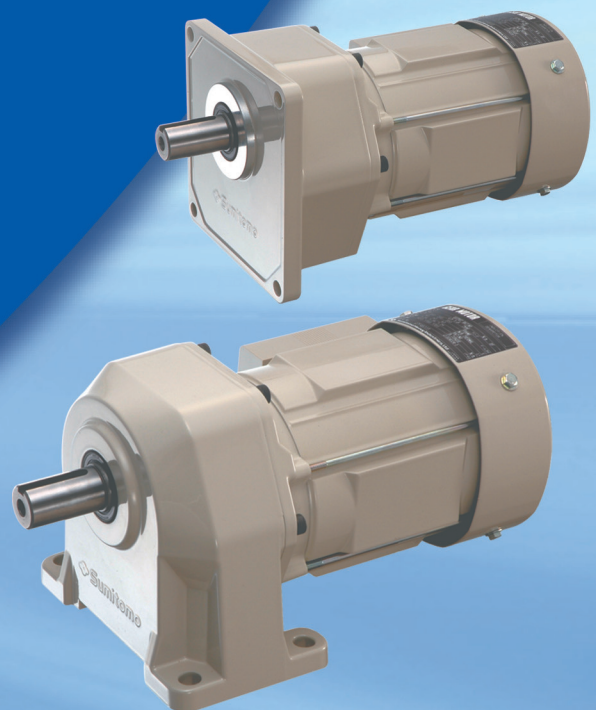

No. Z2302E-1.1

INNOVATIVE PRODUCT WITH UNPARALLELED BENEFITS

Powder coated paint using thermosetting method for higher stain and scratch resistance (does not contain any organic solvent).

Low Noise:

Gears are designed with high contact ratio and high stiffness to lower the noise

Reduced brake noise

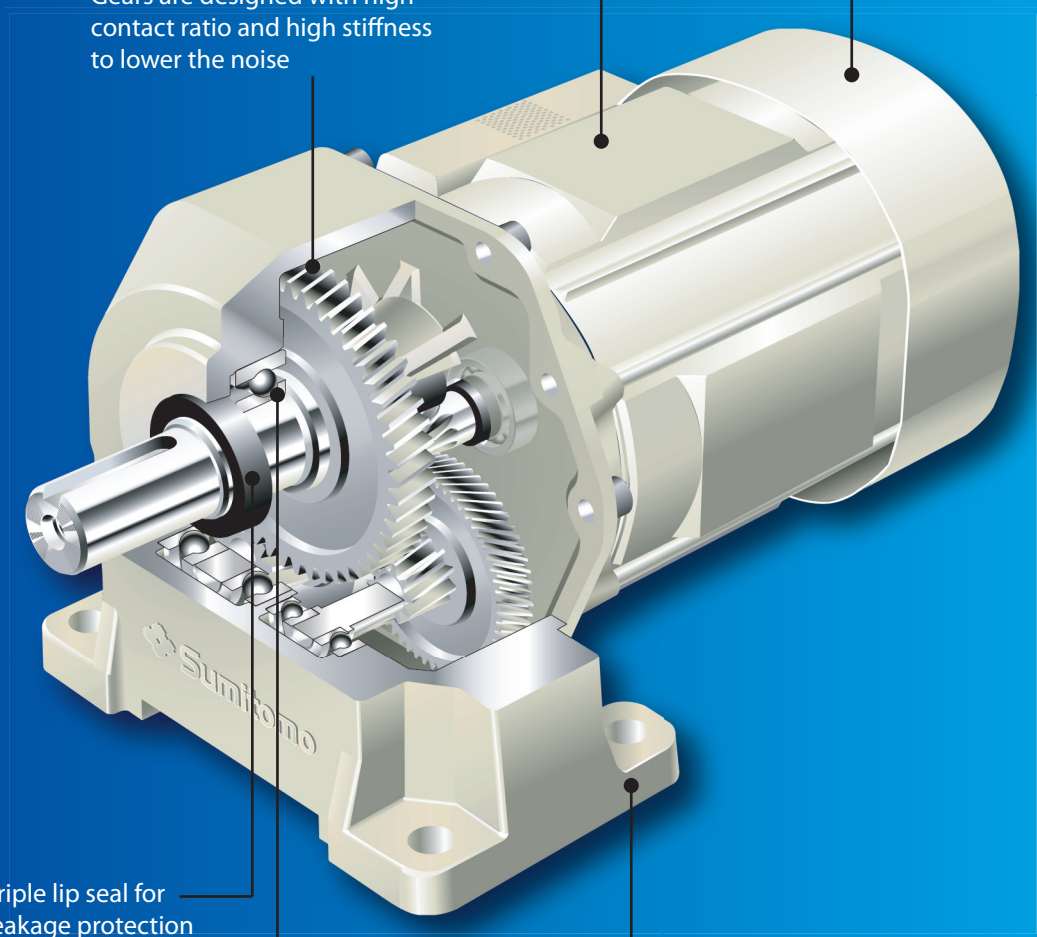

Triple lip seal for leakage protection



3 - Lip Seal

Compact design achieved using high stiffness casing and new motor design

High Radial Load:

High Radial Capacity Bearing and High stiffness casing increase Radial Load Capacity

Table of Contents

1 Features	Inside Cover
2 Product Scope Overview	2
3 Standard Specification	3
4 Nomenclature	4
5 Selection Procedure	6
5.1 Load Factor	7
5.2 Shaft Radial Load	7
5.3 Allowable Start-up Frequency	7
6 Precautions for Driving by Inverter	9
7 Precaution for Mounting	11
8 Output Shaft Rotation Direction	12
9 Selection Tables	
0.1 kW	13
0.2 kW	13
0.4 kW	14
0.75 kW	14
1.5 kW	15
2.2 kW	15
10 Dimension Drawings	
0.1 kW	16 - 17
0.2 kW	18 - 20
0.4 kW	21 - 23
0.75 kW	24 - 26
1.5 kW	27 - 29
2.2 kW	30 - 31
11 Technical Information: Gear Unit	
11.1 Output shaft allowable thrust load	32
11.2 Moment of inertia and GD^2	32
11.3 Output shaft End dimension	33
11.4 Rust proof specification	33
12 Technical Information: Motor	
12.1 Motor Type Designation	34
12.2 Dimension of terminal box	34
12.3 Motor characteristics: CE Marked Motor	35
12.4 Motor characteristics: JIS Specification Motor	36
12.5 Motor characteristics: Increased Safety (eG3) Motor	36
12.6 Built-in Brake Specification	37
12.7 Wiring Diagram: Standard 3-Phase Motor	38
12.8 Wiring Diagram: 3-Phase Motor With Brake	39
12.9 Motor Protection	40
13 Construction Drawing	
13.1 Gear-Motor Construction Drawing	41
13.2 Brake Construction Drawing	41
14 International Standards and Compliance	42
15 Miscellaneous	
15.1 Moment of Inertia	46
15.2 GD^2	47
15.3 Warranty	48
15.4 Safety Precautions	49
15.5 Precautions for applications of special motors	49
15.6 When driving a 400V-class general-purpose motor by an inverter	49

2.0 Product Scope Overview

Indoor type Outdoor type Description in the table: Example Frame number 1220 (φ22) Output shaft diameter (mm)

Motor	Type	Reduction ratio	Output speed																
			3	5	10	15	20	25	30	40	50	60	80	100	120	160	200		
Three-phase motors	Flange mount ZNFM	0.1kW	50Hz	483	290	145	96.7	72.5	58.0	48.3	36.3	29.0	24.2	18.1	14.5	12.1	9.06	7.25	
			60Hz	583	350	175	117	87.5	70.0	58.3	43.8	35.0	29.2	21.9	17.5	14.6	10.9	8.75	
		0.2kW	50Hz	1180 (φ 18)										1220 (φ 22)					
			60Hz	1180 (φ 18)										1221 (φ 22)					
		0.4kW	50Hz	1220 (φ 22)										1280 (φ 28)					
			60Hz	1220 (φ 22)										1281 (φ 28)					
		Foot mount ZNHM	0.75kW	50Hz	1280 (φ 28)										1320 (φ 32)				
	60Hz			1280 (φ 28)										1321 (φ 32)					
	1.5kW		1320 (φ 32)										1400 (φ 40)						
	2.2kW	50Hz	1400 (φ 40)										1500 (φ 50)						
		60Hz	1400 (φ 40)										1501 (φ 50)						

3.0 Standard Specification

Motor Unit

Type	Item	Standard specification	Standard specification with built-in brake
Outdoor, three-phase motors	Capacity range	0.1 kW to 2.2 kW, 4 poles	0.1 kW to 2.2 kW, 4 poles FB, brake (non-asbestos lining)
	Protection method, Enclosure construction	IP55, totally enclosed fan-cooled (0.1 kW: for totally enclosed non-ventilated)	IP55, totally enclosed fan-cooled
	Power supply	50 Hz: 220 ~ 240V / 380 ~ 415V 60 Hz: 230V / 440V	50 Hz: 220 ~ 240V / 380 ~ 415V 60 Hz: 230V / 440V
	Insulation class	F	F
	Time rating	Continuous	Continuous
	Start-up method	Line starting	Line starting
	Lead wires (terminal block type)	6 wires	8 wires
	Standards	IEC	IEC

Gear Unit

Item	Standard specification
Lubrication method	Grease lubrication, filled with special high-grade grease prior to shipment.
Speed reduction method	Parallel shaft gear, speed reduction by involute gears.
Material	Casing: Aluminum alloy (cast iron for frame numbers 1500 and 1501).

Miscellaneous

Items	Standard specification	
Ambient conditions	Installation site	Indoor (free from dust and water) / Outdoor (Vibrations of 1G or lower)
	Ambient temperature	-10 to 40°C Note: When installing the gear motor in an enclosure, ensure that the ambient temperature is 40°C or lower.
	Ambient humidity	85% or lower with no dew condensation.
	Altitude	1,000 m or lower.
	Atmosphere	Free from gas, explosive gas or steam and Well-ventilated.
Installation angle	No limit	
Painting	Painting quality: Epoxy polyester, Painting color: Munsell 5Y8/1 or equivalent (approximate value)	

4.0 Nomenclature

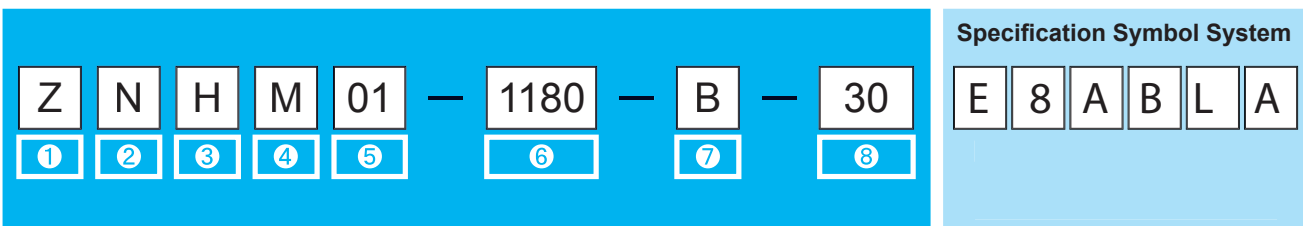

1 Product

PREST NEO | Z

2 Output shaft direction

Universal | N

3 Mounting method	Foot mount H	Flange mount F

4 Input connection

Integral motor | M

5 Motor capacity symbol	Capacity symbol (4-pole)	01	02	05	1	2	3
	kW (HP)	0.1 (1/8)	0.2 (1/4)	0.4 (1/2)	0.75 (1)	1.5 (2)	2.2 (3)

6 Frame number	1180	1220	1221	1280	1281	1320
	1321	1400	1401	1500	1501	

7 With/without brake	Without brake	
	With brake	B
	With fingertip brake release mechanism	C

8 Nominal reduction ratio (For actual reduction ratio, see Selection Tables)

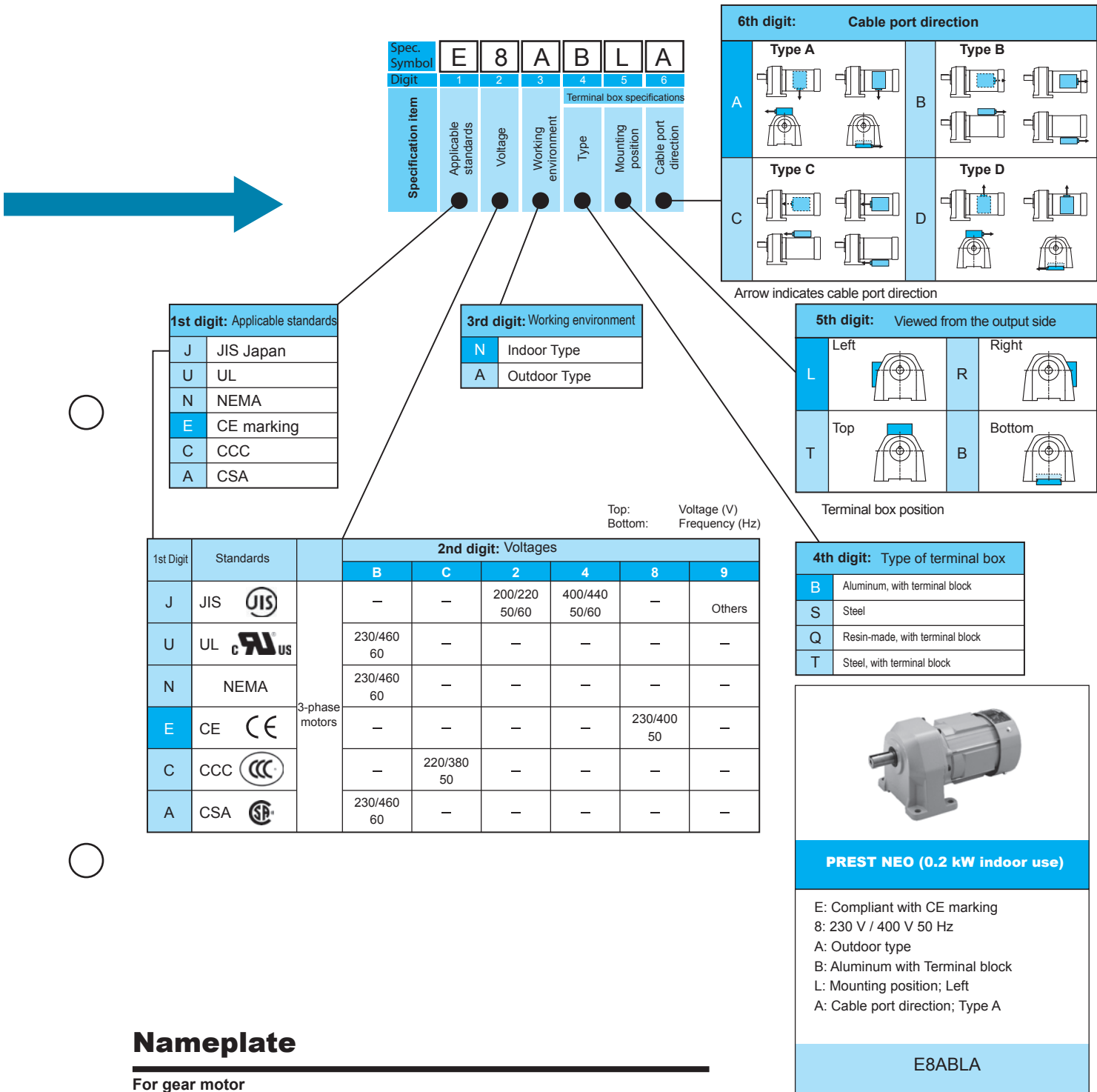

Nameplate

For gear motor

① Nomenclature of gear motor

② Reduction ratio

• Motor capacity

• Motor characteristics

③ Serial number

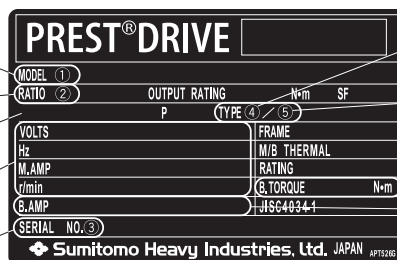

④ Motor type
(see Section 12)

⑤ Brake (if any)

• Brake characteristics
(if any)

5.0 Selection Procedure

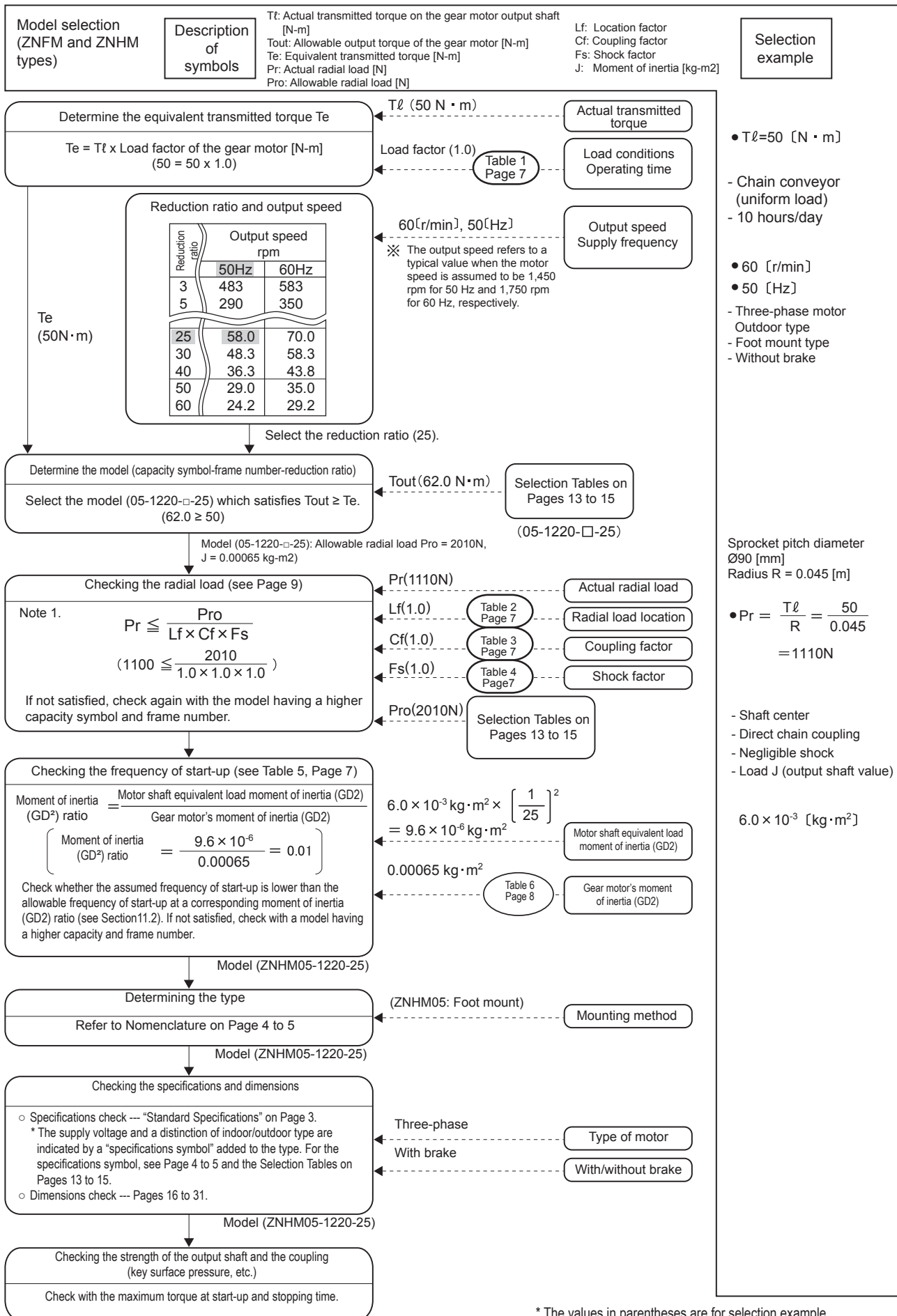

5.0 Selection Procedure

This gear motor has been designed, assuming a uniform load and daily 10-hour operating time.

5.1 Load Factor

Table 1

Operating time Load condition	Less than 10 hours/day	10 to 24 hours/day	Applications
Uniform	1.0	1.25	- Conveyors (uniform load), pumps (centrifugal), food processing machines (rice polishers, canning machines), elevators (uniform load), plastic extruders, agitators (liquid), bar screens.
Light shock	1.25	1.5	- Conveyors (variable speed and heavy load), food processing machines (Vegetable slicers, dough mixers, meat grinders), elevators (heavy load), agitators (liquid-solid mixture, variable density), feeders (belts, aprons, screws), thickeners, flocculators, general machine tools (for spindle).
Heavy shock	1.75	2.0	- Punching presses, tapping machines, crushers (crusher mills), hoists (heavy load), drum barkers, log hauls, cutters, platers.

5.2 Shaft Radial Load

When attaching a chain sprocket or a pulley to this gear motor, check shaft radial load. Ensure that the shaft radial load calculated by the following formula is lower than the output shaft allowable radial load shown in the Selection tables.

$$\text{Shaft radial load } Pr = \frac{Tl \times Lf \times Cf \times Fs}{R} \text{ [N]}$$

Tl : Actual transmitted torque on the gear motor's output shaft

Lf : Load location factor

Cf : Coupling factor

Fs : Shock factor

R : Pitch circle radius of the sprocket, gear, pulley, etc. [m]

Table 2. Location Factor Lf

Load location	Lf
Shaft root	0.8
Shaft center	1.0
Shaft end	1.4

Table 3. Coupling Factor Cf

Coupling method	Cf
Chain	1
Gear	1.25
V-belt	1.5

Table 4. Shock Factor Fs

Degree of shock	Fs
Negligible	1
Light	1~1.2
Heavy	1.4~1.6

5.3 Allowable Start-up Frequency

When load inertia is high, start-up torque increases. If equipped with the brake, braking torque will be high too. The frequency of start-up should be within the tolerance shown in the table below, depending on the coupling method and the degree of inertia of the mating machine. Check also the allowable motor heat capacity on the next page.

Table 5. Allowable Frequency of Start-up

Load coupling method	Moment of inertia (GD2) ratio = $\left(\frac{\text{Motor shaft equivalent load moment of inertia (GD2)}}{\text{Gear motor's moment of inertia (GD2)}} \right)$	Allowable start-up frequency
Direct coupling without backlash	2 1.5 0.6 or lower	5 times/hr. 1 time/min. 10 times/min.
Chain-driven conveyance with backlash	1 0.75 0.4 or lower	5 times/hr. 1 time/min. 7 times/min.

Note: The motor may be started up more frequently than the allowable value for short period only. Contact us for more information.

5.0 Selection Procedure

Table 6. Allowable Heat Capacity of Three-Phase Motors (C x Z)

Motor output kW	Allowable C x Z (35%ED or lower)	Allowable C x Z (Over 35%ED to 50%ED or lower)	Allowable C x Z (Over 50%ED to 80%ED or lower)	Allowable C x Z (Over 80%ED to 100%ED or lower)	Motor's moment of inertia kg-m ²		Motor's GD ² kgf- m ²	
					Standard	With brake	Standard	With brake
0.1	3200	3000	2000	1200	0.00033	0.00035	0.0013	0.0014
0.2	2200	2800	2800	2500	0.00050	0.00055	0.002	0.0022
0.4	1800	2200	1500	1500	0.00065	0.00068	0.0026	0.0027
0.75	1400	1400	800	500	0.00120	0.00130	0.0048	0.0052
1.5	1200	1200	500	400	0.00213	0.00235	0.0085	0.0094
2.2	1000	900	400	200	0.00333	0.00373	0.0133	0.0149

Check that the values of C x Z calculated in (1) to (3) below are within the allowable C x Z in terms of motor capacity and %ED corresponding to Table 6.

(1) Calculate C by the following formula.

$$C = \frac{\text{Motor's moment of inertia (motor's GDM}^2\text{)} + \text{Motor shaft equivalent non-motor's total moment of inertia (GDL}^2\text{)}}{\text{Motor's moment of inertia (motor's GDM}^2\text{)}}$$

[Unit] • Motor's moment of inertia (kg- m²)
GDM²: Motor's GD² (kgf- m²)

• Motor shaft equivalent non-motor's total moment of inertia (kgf- m²)
GDL²: Motor shaft equivalent non-motor's total GD² (kgf- m²)



(2) Calculate an hourly start count Z (times/hr.).

(a) Assume that one-cycle operating time is t_a (sec.), rest time is t_b (sec.) and the motor is started n_r times (times/cycle) during this period;

$$Z_r = \frac{3600n_r}{t_a + t_b} \text{ (times/hr.)}$$

(b) When an inching count n_i (times/cycle) in one cycle period (t_a + t_b), convert it to a start count equivalent to an hourly inching count Z_i.

$$Z_i = \frac{3600n_i}{t_a + t_b} \text{ (times/hr.)}$$

(c) Calculate an hourly start count Z (times/hr.) based on (a) and (b).

$$Z = Z_r + 1/2 \cdot Z_i = \frac{3600}{t_a + t_b} \cdot (n_r + \frac{1}{2} n_i) \text{ (times/hr.)}$$

(3) Calculate C x Z; calculate a product C x Z of C calculated in (1) and Z calculated in (2).

(4) Duty cycle %ED : %ED = $\frac{t_a}{t_a + t_b} \times 100$



6.0 Precautions for Driving by Inverter

6.1 Constant torque operation

The sensorless operation mode of our inverter HF-320 α permits constant torque operation of a general-purpose motor at 3.7 kW or less. When operating in a low frequency range of less than 6 Hz, consult us.

6.2 Operation in frequency range exceeding the base frequency (60 Hz)

Constant output operation is performed in a frequency range exceeding a base frequency. Accordingly, a torque decreases as the motor runs at higher speed. Select a motor capacity according to machine load characteristics. (See Fig. 2)

(See Fig. 2)

When constant torque operation is performed, assuming a frequency over 60 Hz to be the base frequency and setting V/f, an output torque will be lower than at the time of standard 60 Hz base frequency. Such adjustment may cause an insufficient torque at low frequency or insufficient starting torque. Do not change the base frequency value in cases of other than reduced load characteristics.

6.3 V/f mode operation of general-purpose inverter

When performing multi-operation of the motor or V/f operation by an inverter having no sensorless function, it is necessary to adjust a boost value in compensation for a starting torque and a low-speed torque. Normally, the motor is shipped from the factory with the standard boost value, an overcurrent may result depending on the load and acceleration/deceleration condition. If this is the case, change the boost value appropriately in the following manner.

- For a low-capacity motor with a light load, high boost setting may cause overexcitation of the motor, triggering an overcurrent. If this is the case, lower the boost setting to a normal value.
- When a load is heavy and the motor tends to trip due to an overcurrent at the time of starting or running at low speed, a current value may be lower by increasing the boost setting. If no effect of improvement results from boost adjustment, it is necessary to review a motor capacity.

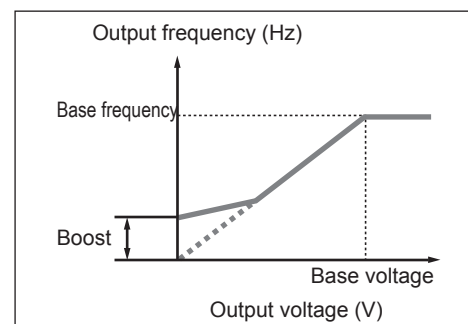

Fig. 1

6.4 Operation by sensorless vector inverter

Some up-to-date high-performance inverters are equipped with a sensorless vector operation function. This function is basically valid only when a motor and an inverter are operated one-on-one. It is not suitable for multi-operation or pole-change operation.

Generally, the products with an auto-tuning method automatically adjust motor characteristics, requiring no adjustment made at the time of V/f operation. Since the inverter performs vector operation based on the read motor data, suitable control for the load condition is enabled instantaneously, providing optimum operation.

If wiring distance is long (20 m or more) between the motor and the inverter, however, compensation may be required in line with a line impedance drop. When the wiring distance is long, select a sufficiently large wire size.

6.5 Motor output torque characteristics

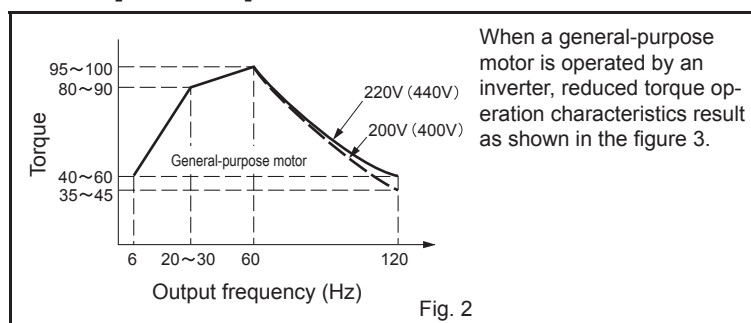

Fig. 2

6.6 Motor temperature rise

When a general purpose motor is combined with an inverter for variable speed operation, a motor temperature rise is slightly greater than when operated on the commercial power. The following are possible factors.

Effect of an output waveform -----

Unlike the commercial power, the output waveform of the inverter is not a complete sine waveform and includes harmonic components, resulting in a greater motor loss and slightly higher temperature.

Decrease motor cooling effect in low-speed operation ---

The motor is cooled by the fan of the motor body. If the motor speed is lowered by the inverter, a cooling air volume will drop, reducing a cooling effect.

6.0 Precautions for Driving by Inverter

Operation of the general-purpose motor by the inverter

Operation with the following characteristics is possible when our HF-320 α series inverter is combined with this gear motor to provide sensorless control.

- Note:
1. When operating a 400 V-class motor by an inverter, contact us for motor insulation.
 2. When operating a motor with brake at low speed for a long time, a cooling effect of a motor fan drops and the temperature of the brake rises more. Contact us for details.
 3. Contact us for details when performing constant torque operation of this gear motor by V/F control. (Contact us also when using our SF-320 α series inverter.)

Table 7

kW	Motor frame	Heat resistance class	Available frequency range	Applicable inverter
0.1	V-63S	F	6 to 120 Hz (Base frequency 60 Hz)	HF-320 α series
0.2	V-63M			
0.4	V-71M			
0.75	V-80M	F		
1.5	V-90L			
2.2	V-100L			

6.7 HF-320 α Output Torque Characteristics in Sensorless Mode Operation (Single Motor Unit)

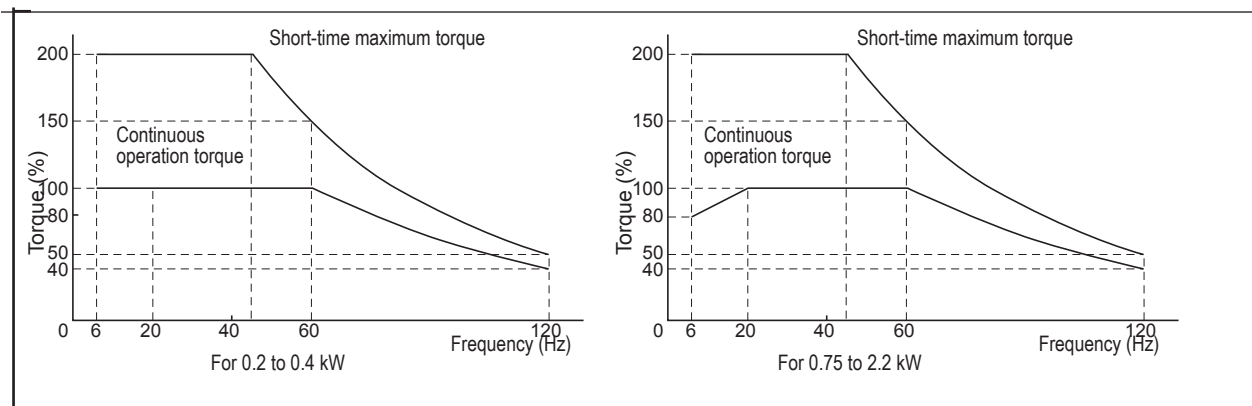

Fig. 3

- A combination output torque assumes that the rating is 100% when the motor's frequency is 60(Hz).
- Contact us for the motors with brake.

7.0 Precaution for Mounting

7.1 When using a Coupling

- When mounting a coupling, care should be taken not to impact or apply an excessive thrust load to the shaft. Otherwise, the bearing may be damaged.
- It is recommended to mount the coupling by shrink fit or an end cap screw (Fig. 4).

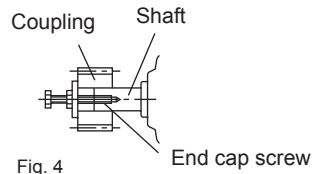

1. When using a coupling, the dimensions (A, B, X) in Fig. 5 should be within the accuracy shown in Table 8.

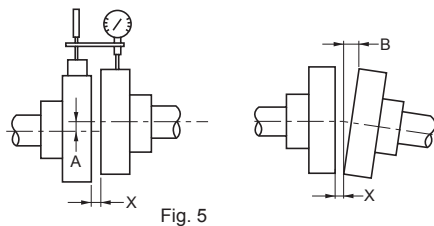
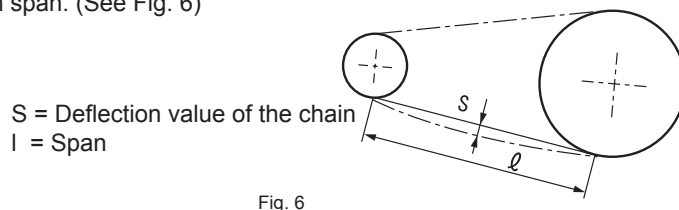

Table 8. Flexible Coupling Centering Accuracy

Dimension-A tolerance	0.1 mm or manufacturer's specification
Dimension-B tolerance	0.1 mm or manufacturer's specification
Dimension-X	Manufacturer's specification

7.2 When using a chain sprocket and gear

- For the chain type, ensure that a chain tension angle is perpendicular to the shaft.
- Chain tension
When using a chain, beware of its deflection value. If the deflection value is high, a big impact will result at the time of start-up or load fluctuation, adversely affecting a reducer or a mating machine. Normally, ensure that the deflection value is about 2% of a chain span. (See Fig. 6)



Chain layout

The chain sprockets may be freely laid out. For a horizontal layout, the upper part should be tensed. A vertical layout of the chain sprockets should be avoided as much as possible, but if it is inevitable, it is desired to arrange a larger sprocket at a lower position regardless of a rotating direction. (See Fig. 7)

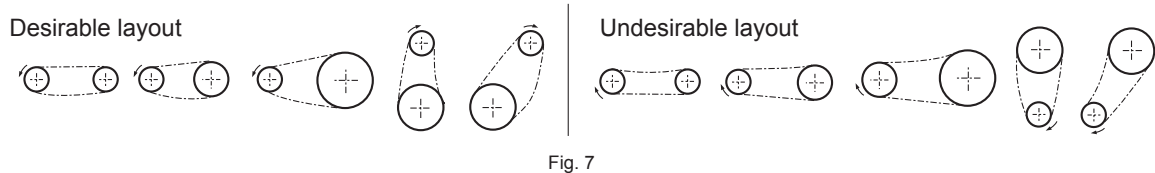

- Select the sprockets and gears whose circular pitch diameters are more than 3 times greater than a shaft diameter.
- Ensure that the load application point of the sprockets and gears is located closer to the gear motor side from the shaft center. (See Fig. 8)

7.3 When using a V-belt

- An excessive V-belt tension damages the shaft and bearing. For a proper tension, see a catalog, etc. for the V-belt used.
- The parallelism and eccentricity (β) between both pulleys should be within $20'$. (See Fig. 9)
- To install multiple V-belts, use a matched set of them having the same circumferential length.

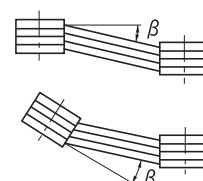
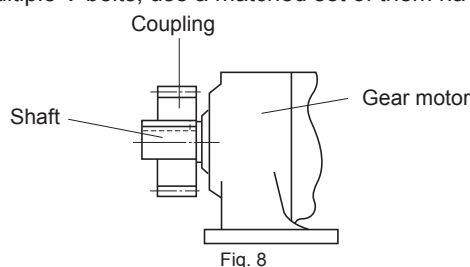

8.0 Output Shaft Rotation Direction

Output Shaft Rotation Direction

Table 9

If the wires are connected exactly as shown on Page 38 the motor shaft rotates in the clockwise direction, viewed from the fan cover side. At this time, the output shaft rotates in an arrow-indicated direction in the following figure.

Frame no.	Reduction ratio	
1180	3, 5, 10, 15, 20, 25, 30, 40, 50	—
1220	3, 5, 10, 15, 20, 25, 30	60, 80, 100, 120, 160, 200
1221	30	40, 50, 60, 80, 100
1280	3, 5, 10, 15, 20, 25, 30	100, 120, 160, 200
1281	30	40, 50, 60, 80, 100
1320	3, 5, 10, 15, 20, 25, 30	100, 120, 160, 200
1321	30	40, 50, 60, 80, 100
1400	3, 5, 10, 15, 20, 25, 30	100, 120, 160, 200
1401	30	40, 50, 60, 80, 100
1500	—	100, 120, 160, 200
1501	30	40, 50, 60, 80, 100

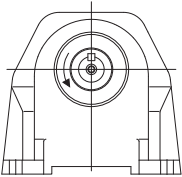
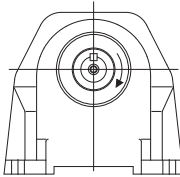
Output shaft rotating direction (Viewed from the output shaft side)	 <p>Rotates in the same direction as the motor shaft.</p>	 <p>Rotates in the opposite direction of the motor shaft.</p>
--	---	---



9.0 Selection Table

0.1kW

Motor Speed n_1	50Hz	1450r/min
	60Hz	1750r/min

50Hz					60Hz					Nomenclature			Exact Ratio	Outline Dimension Fig	
Output Speed n_2	Output Torque Tout		Allowable Radial Load Pro		Output Speed n_2	Output Torque Tout		Allowable Radial Load Pro		Input Capacity Symbol	Frame Size	Reduction Ratio		ZNFM	ZNHM
r/min	N.m	kgf.m	N	Kgf	r/min	N.m	kgf.m	N	Kgf						
483	1.78	0.182	690	70	583	1.48	0.150	690	70	01 - 1180 (-B)	- 3	2.91	Fig D1 Page 16	Fig D2 Page 16	
290	2.97	0.303	810	83	350	2.46	0.251	810	83	01 - 1180 (-B)	- 5	5.03			
145	6.20	0.632	1060	108	175	5.14	0.524	1060	108	01 - 1180 (-B)	- 10	10.20			
96.7	9.30	0.948	1250	127	117	7.70	0.786	1250	127	01 - 1180 (-B)	- 15	14.52			
72.5	12.4	1.26	1420	145	87.5	10.3	1.05	1420	145	01 - 1180 (-B)	- 20	20.57			
58.0	15.5	1.58	1530	156	70.0	12.8	1.31	1530	156	01 - 1180 (-B)	- 25	24.44			
48.3	18.6	1.90	1650	168	58.3	15.4	1.57	1650	168	01 - 1180 (-B)	- 30	30.40			
36.3	24.8	2.53	1800	184	43.8	20.5	2.09	1800	184	01 - 1180 (-B)	- 40	41.53			
29.0	31.0	3.16	1890	193	35.0	25.7	2.62	1890	193	01 - 1180 (-B)	- 50	48.57			
24.2	36.0	3.67	2700	275	29.2	29.8	3.04	2700	275	01 - 1220 (-B)	- 60	60.22	Fig D3 Page 17	Fig D4 Page 17	
18.1	48.0	4.90	2940	300	21.9	39.8	4.06	2940	300	01 - 1220 (-B)	- 80	77.38			
14.5	60.0	6.12	2940	300	17.5	49.7	5.07	2940	300	01 - 1220 (-B)	- 100	101.64			
12.1	72.0	7.34	2940	300	14.6	59.7	6.08	2940	300	01 - 1220 (-B)	- 120	115.75			
9.06	96.0	9.79	2940	300	10.9	79.6	8.11	2940	300	01 - 1220 (-B)	- 160	154.13			
7.25	120	12.2	2940	300	8.75	99.4	10.1	2940	300	01 - 1220 (-B)	- 200	192.50			

Note) 1. The output speed is a typical value when the motor speed is 1,450 rpm for 50 Hz and 1,750 rpm for 60 Hz. For actual motor speed, refer to section 12.
 2. The output shaft allowable radial load refers to a value at the center of the output shaft.
 3. A value in parentheses indicates the motor type with brake.

0.2kW

Motor Speed n_1	50Hz	1450r/min
	60Hz	1750r/min

50Hz					60Hz					Nomenclature			Exact Ratio	Outline Dimension Fig	
Output Speed n_2	Output Torque Tout		Allowable Radial Load Pro		Output Speed n_2	Output Torque Tout		Allowable Radial Load Pro		Input Capacity Symbol	Frame Size	Reduction Ratio		ZNFM	ZNHM
r/min	N.m	kgf.m	N	Kgf	r/min	N.m	kgf.m	N	Kgf						
483	3.56	0.363	690	70	583	2.95	0.301	690	70	02 - 1180 (-B)	- 3	2.91	Fig D5 Page 18	Fig D6 Page 18	
290	5.93	0.605	810	83	350	4.92	0.501	810	83	02 - 1180 (-B)	- 5	5.03			
145	12.4	1.26	1060	108	175	10.3	1.05	1060	108	02 - 1180 (-B)	- 10	10.20			
96.7	18.6	1.90	1250	127	117	15.4	1.57	1250	127	02 - 1180 (-B)	- 15	14.52			
72.5	24.8	2.53	1420	145	87.5	20.5	2.09	1420	145	02 - 1180 (-B)	- 20	20.57	Fig D7 Page 19	Fig D8 Page 19	
58.0	31.0	3.16	1530	156	70.0	25.7	2.62	1530	156	02 - 1180 (-B)	- 25	24.44			
48.3	37.2	3.79	1650	168	58.3	30.8	3.14	1650	168	02 - 1180 (-B)	- 30	30.40			
48.3	37.2	3.79	2120	216	58.3	30.8	3.14	2120	216	02 - 1221 (-B)	- 30	31.11	Fig D9 Page 20	Fig D10 Page 20	
36.3	48.0	4.90	2300	235	43.8	39.8	4.06	2300	235	02 - 1221 (-B)	- 40	40.39			
29.0	60.0	6.12	2500	255	35.0	49.7	5.07	2500	255	02 - 1221 (-B)	- 50	51.02			
24.2	72.0	7.34	2700	275	29.2	59.7	6.08	2700	275	02 - 1221 (-B)	- 60	60.42	Fig D9 Page 20	Fig D10 Page 20	
18.1	96.0	9.79	2940	300	21.9	79.6	8.11	2940	300	02 - 1221 (-B)	- 80	80.46			
14.5	120	12.2	2940	300	17.5	99.4	10.1	2940	300	02 - 1221 (-B)	- 100	101.63			
14.5	120	12.2	3410	348	17.5	99.4	10.1	3410	348	02 - 1280 (-B)	- 100	97.33	Fig D9 Page 20	Fig D10 Page 20	
12.1	144	14.7	4000	408	14.6	119	12.2	4000	408	02 - 1280 (-B)	- 120	116.80			
9.06	192	19.6	4120	420	10.9	159	16.2	4120	420	02 - 1280 (-B)	- 160	159.27	Fig D9 Page 20	Fig D10 Page 20	
7.25	240	24.5	4120	420	8.75	199	20.3	4120	420	02 - 1280 (-B)	- 200	198.99			

Note) 1. The output speed is a typical value when the motor speed is 1,450 rpm for 50 Hz and 1,750 rpm for 60 Hz. For actual motor speed, refer to section 12.
 2. The output shaft allowable radial load refers to a value at the center of the output shaft.
 3. A value in parentheses indicates the motor type with brake.

9.0 Selection Table

0.4kW

Motor Speed n ₁	50Hz	1450r/min
	60Hz	1750r/min

50Hz					60Hz					Nomenclature			Exact Ratio	Outline Dimension Fig							
Output Speed n ₂	Output Torque Tout		Allowable Radial Load Pro		Output Speed n ₂	Output Torque Tout		Allowable Radial Load Pro		Input Capacity Symbol	Frame Size	Reduction Ratio		ZNFM	ZNHM						
r/min	N.m	kgf.m	N	Kgf	r/min	N.m	kgf.m	N	Kgf												
483	7.12	0.726	820	84	583	5.90	0.602	700	71	05 - 1220 (-B) - 3 05 - 1220 (-B) - 5 05 - 1220 (-B) - 10	-	3	3.10	Fig D11 Page 21	Fig D12 Page 21						
290	11.9	1.21	1060	108	350	9.83	1.00	1060	108							-	5	4.94			
145	24.8	2.53	1420	145	175	20.5	2.09	1420	145										-	10	9.79
96.7	37.2	3.79	1650	168	117	30.8	3.14	1650	168	05 - 1220 (-B) - 15 05 - 1220 (-B) - 20 05 - 1220 (-B) - 25 05 - 1220 (-B) - 30	-	15	14.65	Fig D11 Page 21	Fig D12 Page 21						
72.5	49.6	5.06	1840	188	87.5	41.1	4.19	1840	188							-	20	19.51			
58.0	62.0	6.32	2010	205	70.0	51.4	5.24	2010	205										-	25	24.37
48.3	74.4	7.58	2120	216	58.3	61.6	6.28	2120	216												
48.3	74.4	7.58	3060	312	58.3	61.6	6.28	3060	312	05 - 1281 (-B) - 30 05 - 1281 (-B) - 40 05 - 1281 (-B) - 50	-	30	29.24	Fig D13 Page 22	Fig D14 Page 22						
36.3	96.0	9.79	3410	348	43.8	79.6	8.11	3410	348							-	40	41.28			
29.0	120	12.2	3770	384	35.0	99.4	10.1	3770	384										-	50	50.35
24.2	144	14.7	4120	420	29.2	119	12.2	4120	420	05 - 1281 (-B) - 60 05 - 1281 (-B) - 80 05 - 1281 (-B) - 100	-	60	58.67	Fig D13 Page 22	Fig D14 Page 22						
18.1	192	19.6	4120	420	21.9	159	16.2	4120	420							-	80	80.00			
14.5	240	24.5	4120	420	17.5	199	20.3	4120	420										-	100	97.58
14.5	240	24.5	5880	600	17.5	199	20.3	5880	600	05 - 1320 (-B) - 100 05 - 1320 (-B) - 120	-	100	100.92	Fig D15 Page 23	Fig D16 Page 23						
12.1	288	29.4	7060	720	14.6	239	24.3	7060	720							-	120	117.80			
9.06	384	39.2	7060	720	10.9	318	32.4	7060	720	05 - 1320 (-B) - 160 02 - 1320 (-B) - 200	-	160	156.44	Fig D15 Page 23	Fig D16 Page 23						
7.25	480	49.0	7060	720	8.75	398	40.6	7060	720							-	200	195.19			

- Note) 1. The output speed is a typical value when the motor speed is 1,450 rpm for 50 Hz and 1,750 rpm for 60 Hz. For actual motor speed, refer to section 12.
 2. The output shaft allowable radial load refers to a value at the center of the output shaft.
 3. A value in parentheses indicates the motor type with brake.

0.75kW

Motor Speed n ₁	50Hz	1450r/min
	60Hz	1750r/min

50Hz					60Hz					Nomenclature			Exact Ratio	Outline Dimension Fig							
Output Speed n ₂	Output Torque Tout		Allowable Radial Load Pro		Output Speed n ₂	Output Torque Tout		Allowable Radial Load Pro		Input Capacity Symbol	Frame Size	Reduction Ratio		ZNFM	ZNHM						
r/min	N.m	kgf.m	N	Kgf	r/min	N.m	kgf.m	N	Kgf												
483	13.4	1.36	650	66	583	11.1	1.13	500	51	1 - 1280 (-B) - 3 1 - 1280 (-B) - 5 1 - 1280 (-B) - 10	-	3	3.02	Fig D17 Page 24	Fig D18 Page 24						
290	22.3	2.27	1270	130	350	18.4	1.88	1000	102							-	5	4.89			
145	46.5	4.74	2120	216	175	38.5	3.93	2120	216										-	10	10.32
96.7	69.7	7.11	2600	265	117	57.8	5.89	2600	265	1 - 1280 (-B) - 15 1 - 1280 (-B) - 20 1 - 1280 (-B) - 25 1 - 1280 (-B) - 30	-	15	14.67	Fig D17 Page 24	Fig D18 Page 24						
72.5	93.0	9.48	2820	288	87.5	77.0	7.86	2820	288							-	20	20.00			
58.0	116	11.9	2940	300	70.0	96.3	9.82	2940	300										-	25	24.99
48.3	139	14.2	3060	312	58.3	116	11.8	3060	312												
48.3	139	14.2	4830	493	58.3	116	11.8	4830	493	1 - 1321 (-B) - 30 1 - 1321 (-B) - 40 1 - 1321 (-B) - 50	-	30	30.85	Fig D19 Page 25	Fig D20 Page 25						
36.3	180	18.4	5430	554	43.8	149	15.2	5430	554							-	40	40.71			
29.0	225	22.9	6030	615	35.0	186	19.0	6030	615										-	50	50.46
24.2	270	27.5	6590	672	29.2	224	22.8	6590	672	1 - 1321 (-B) - 60 1 - 1321 (-B) - 80 1 - 1321 (-B) - 100	-	60	58.72	Fig D19 Page 25	Fig D20 Page 25						
18.1	360	36.7	7060	720	21.9	298	30.4	7060	720							-	80	77.99			
14.5	450	45.9	7060	720	17.5	373	38.0	7060	720										-	100	96.66
14.5	450	45.9	8480	865	17.5	373	38.0	8480	865	1 - 1400 (-B) - 100 1 - 1400 (-B) - 120	-	100	101.39	Fig D21 Page 26	Fig D22 Page 26						
12.1	540	55.1	8480	865	14.6	447	45.6	8480	865							-	120	115.35			
9.06	720	73.4	8480	865	10.9	597	60.8	8480	865	1 - 1400 (-B) - 160 1 - 1400 (-B) - 200	-	160	157.05	Fig D21 Page 26	Fig D22 Page 26						
7.25	*769	*78.4	8480	865	8.75	746	76.1	8480	865							-	200	196.12			

- Note) 1. The output speed is a typical value when the motor speed is 1,450 rpm for 50 Hz and 1,750 rpm for 60 Hz. For actual motor speed, refer to section 12.
 2. The output shaft allowable radial load refers to a value at the center of the output shaft.
 3. A value in parentheses indicates the motor type with brake.
 4. Value with * indicate the maximum output torque capacity of gearhead. Please ensure application torque is not over this value.

9.0 Selection Table

1.5kW

Motor Speed n_1	50Hz	1450r/min
	60Hz	1750r/min

50Hz					60Hz					Nomenclature			Exact Ratio	Outline Dimension Fig							
Output Speed n_2	Output Torque Tout		Allowable Radial Load Pro		Output Speed n_2	Output Torque Tout		Allowable Radial Load Pro		Input Capacity Symbol	Frame Size	Reduction Ratio		ZNFM	ZNHM						
r/min	N.m	kgf.m	N	Kgf	r/min	N.m	kgf.m	N	Kgf												
483	26.7	2.72	1090	111	583	22.1	2.26	850	87	2 - 1320 (-B) - 3 2 - 1320 (-B) - 5 2 - 1320 (-B) - 10	-	3	2.94	Fig D23 Page 27	Fig D24 Page 27						
290	44.5	4.54	2070	211	350	36.9	3.76	1760	179							-	5	5.04			
145	93.0	9.48	2940	300	175	77.0	7.86	2940	300										-	10	10.38
96.7	139	14.2	3500	357	117	116	11.8	3500	357	2 - 1320 (-B) - 15 2 - 1320 (-B) - 20 2 - 1320 (-B) - 25 2 - 1320 (-B) - 30	-	15	14.97	Fig D25 Page 28	Fig D26 Page 28						
72.5	186	19.0	4100	418	87.5	154	15.7	4100	418							-	20	19.88			
58.0	232	23.7	4590	468	70.0	193	19.6	4590	468										-	25	24.80
48.3	279	28.4	4830	493	58.3	231	23.6	4830	493												
48.3	279	28.4	6120	624	58.3	231	23.6	6120	624	2 - 1401 (-B) - 30 2 - 1401 (-B) - 40 2 - 1401 (-B) - 50	-	30	30.75	Fig D27 Page 29	Fig D28 Page 29						
36.3	360	36.7	7060	720	43.8	298	30.4	7060	720							-	40	39.54			
29.0	450	45.9	7330	747	35.0	373	38.0	7330	747										-	50	49.07
24.2	540	55.1	7720	787	29.2	447	45.6	7720	787	2 - 1401 (-B) - 60 2 - 1401 (-B) - 80 2 - 1401 (-B) - 100	-	60	60.72	Fig D27 Page 29	Fig D28 Page 29						
18.1	720	73.4	7900	805	21.9	597	60.8	7900	805							-	80	82.67			
14.5	*769	*78.4	8480	865	17.5	746	76.1	8480	865										-	100	102.61
14.5	900	91.8	11800	1203	17.5	746	76.1	11800	1203	2 - 1500 (-B) - 100 2 - 1500 (-B) - 120	-	100	101.74	Fig D27 Page 29	Fig D28 Page 29						
12.1	1080	110	11800	1203	14.6	895	91.3	11800	1203							-	120	118.10			
9.06	*1230	*125	11800	1203	10.9	1193	122	11800	1203	2 - 1500 (-B) - 160 2 - 1500 (-B) - 200	-	160	159.21	Fig D27 Page 29	Fig D28 Page 29						
7.25	*1230	*125	11800	1203	8.75	*1230	*125	11800	1203							-	200	199.01			

- Note) 1. The output speed is a typical value when the motor speed is 1,450 rpm for 50 Hz and 1,750 rpm for 60 Hz. For actual motor speed, refer to section 12.
 2. The output shaft allowable radial load refers to a value at the center of the output shaft.
 3. A value in parentheses indicates the motor type with brake.
 4. Value with * indicate the maximum output torque capacity of gearhead. Please ensure application torque is not over this value.

2.2kW

Motor Speed n_1	50Hz	1450r/min
	60Hz	1750r/min

50Hz					60Hz					Nomenclature			Exact Ratio	Outline Dimension Fig							
Output Speed n_2	Output Torque Tout		Allowable Radial Load Pro		Output Speed n_2	Output Torque Tout		Allowable Radial Load Pro		Input Capacity Symbol	Frame Size	Reduction Ratio		ZNFM	ZNHM						
r/min	N.m	kgf.m	N	Kgf	r/min	N.m	kgf.m	N	Kgf												
483	39.2	3.99	1170	119	583	32.5	3.31	900	92	3 - 1400 (-B) - 3 3 - 1400 (-B) - 5 3 - 1400 (-B) - 10	-	3	3.07	Fig D29 Page 30	Fig D30 Page 30						
290	65.3	6.66	2230	227	350	54.1	5.52	1800	184							-	5	5.06			
145	136	13.9	3770	384	175	113	11.5	3770	384										-	10	9.78
96.7	205	20.9	4500	459	117	169	17.3	4500	459	3 - 1400 (-B) - 15 3 - 1400 (-B) - 20 3 - 1400 (-B) - 25 3 - 1400 (-B) - 30	-	15	15.02	Fig D31 Page 31	Fig D32 Page 31						
72.5	273	27.8	5070	517	87.5	226	23.0	5070	517							-	20	20.44			
58.0	341	34.8	5640	575	70.0	282	28.8	5640	575										-	25	25.53
48.3	409	41.7	6120	624	58.3	339	34.6	6120	624												
48.3	409	41.7	8360	852	58.3	339	34.6	8360	852	3 - 1501 (-B) - 30 3 - 1501 (-B) - 40 3 - 1501 (-B) - 50	-	30	28.89	Fig D31 Page 31	Fig D32 Page 31						
36.3	528	53.8	9510	970	43.8	438	44.6	9510	970							-	40	39.62			
29.0	660	67.3	10660	1087	35.0	547	55.8	10660	1087										-	50	48.15
24.2	792	80.8	11800	1203	29.2	656	66.9	11800	1203	3 - 1501 (-B) - 60 3 - 1501 (-B) - 80 3 - 1501 (-B) - 100	-	60	59.43	Fig D31 Page 31	Fig D32 Page 31						
18.1	1056	108	11800	1203	21.9	875	89.2	11800	1203							-	80	79.24			
14.5	*1230	*125	11800	1203	17.5	1094	112	11800	1203										-	100	96.30

- Note) 1. The output speed is a typical value when the motor speed is 1,450 rpm for 50 Hz and 1,750 rpm for 60 Hz. For actual motor speed, refer to section 12.
 2. The output shaft allowable radial load refers to a value at the center of the output shaft.
 3. A value in parentheses indicates the motor type with brake.
 4. Value with * indicate the maximum output torque capacity of gearhead. Please ensure application torque is not over this value.

10.0 Dimension Drawings

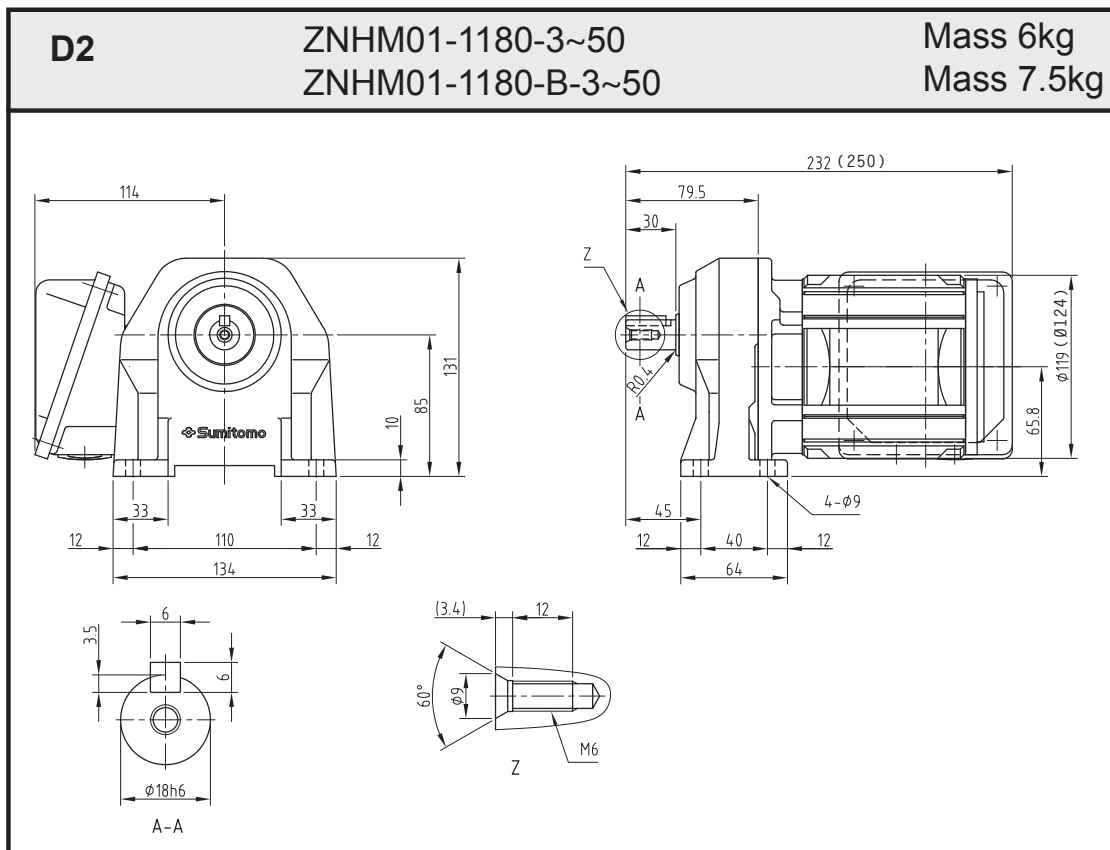
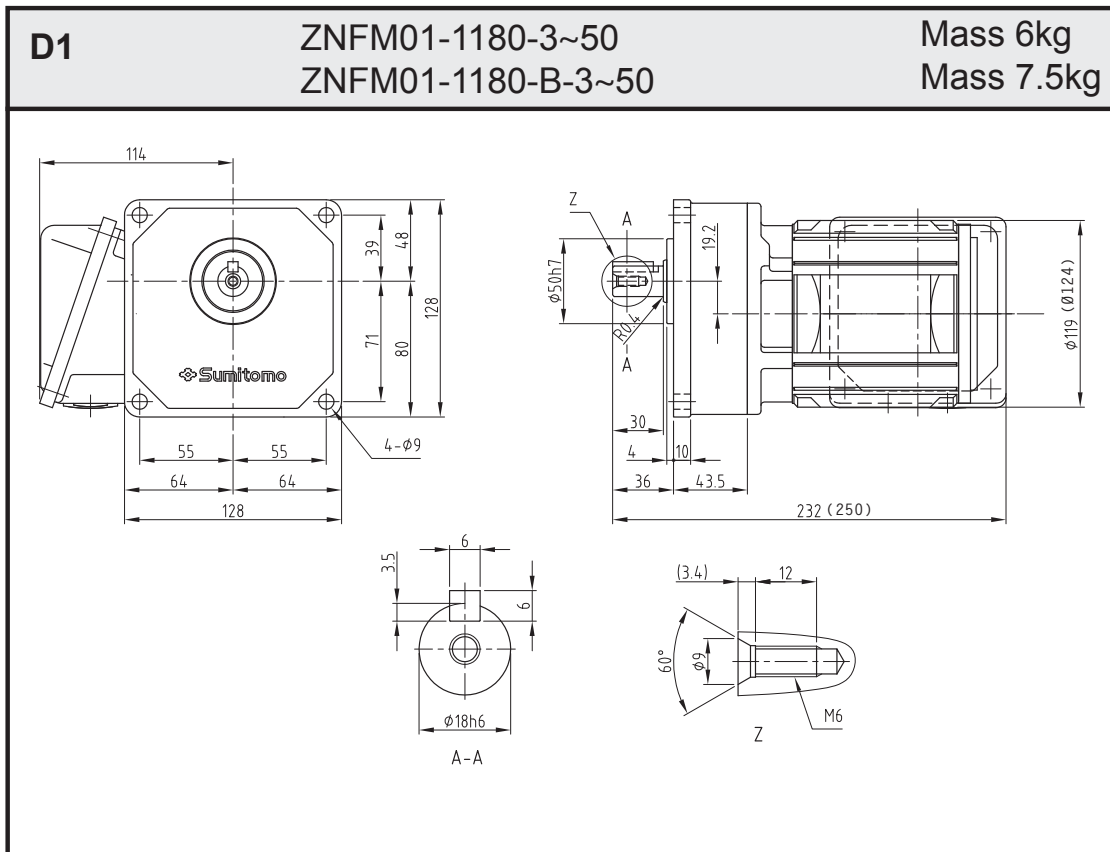

- Note) 1. Output shaft diameter: Dimension tolerance compliant with the JIS B 0401-1998 "h6."
 2. Shaft end key dimensions: Dimension tolerance compliant with the JIS B 1301-1996 "Parallel Keys."
 3. For the detailed dimensions of the output shaft section, see Page 33 of Technical Information.
 4. The dimensions and masses in the dimensions drawings are subject to change without prior notice.
 5. Values in parentheses indicate the type, dimensions and mass of the motor with brake.

10.0 Dimension Drawings

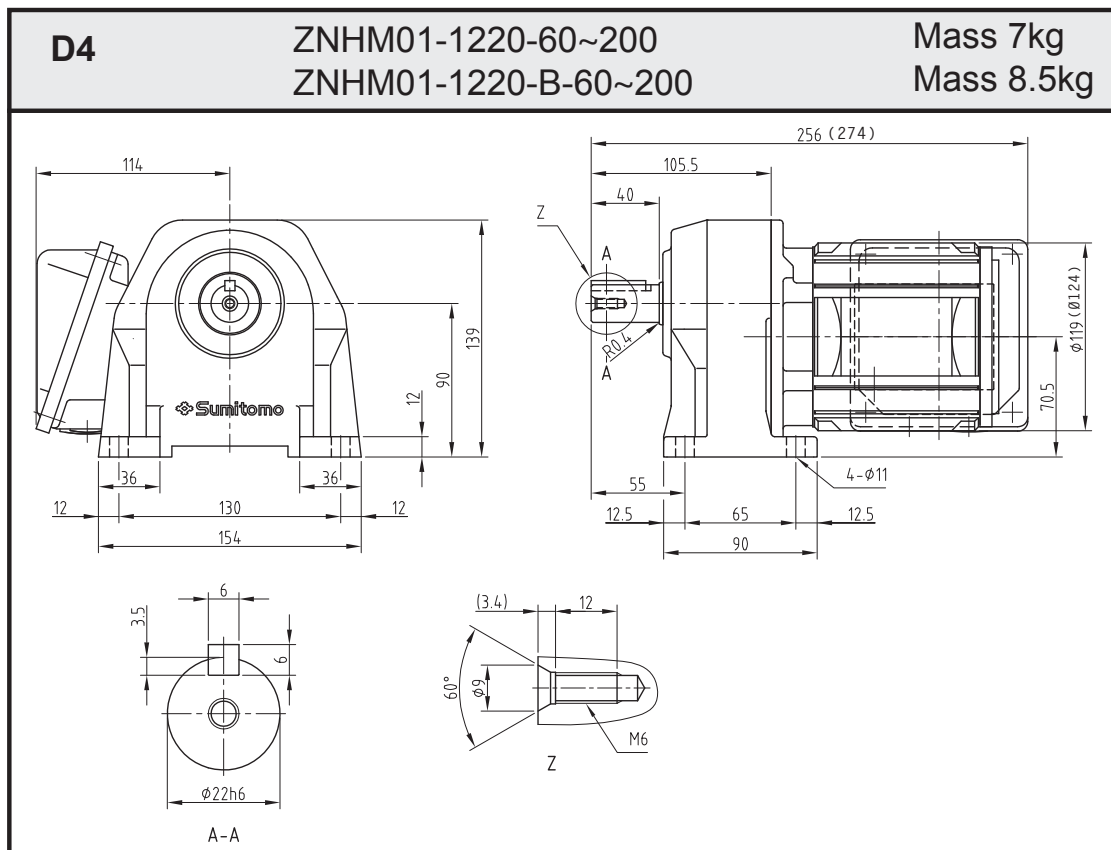
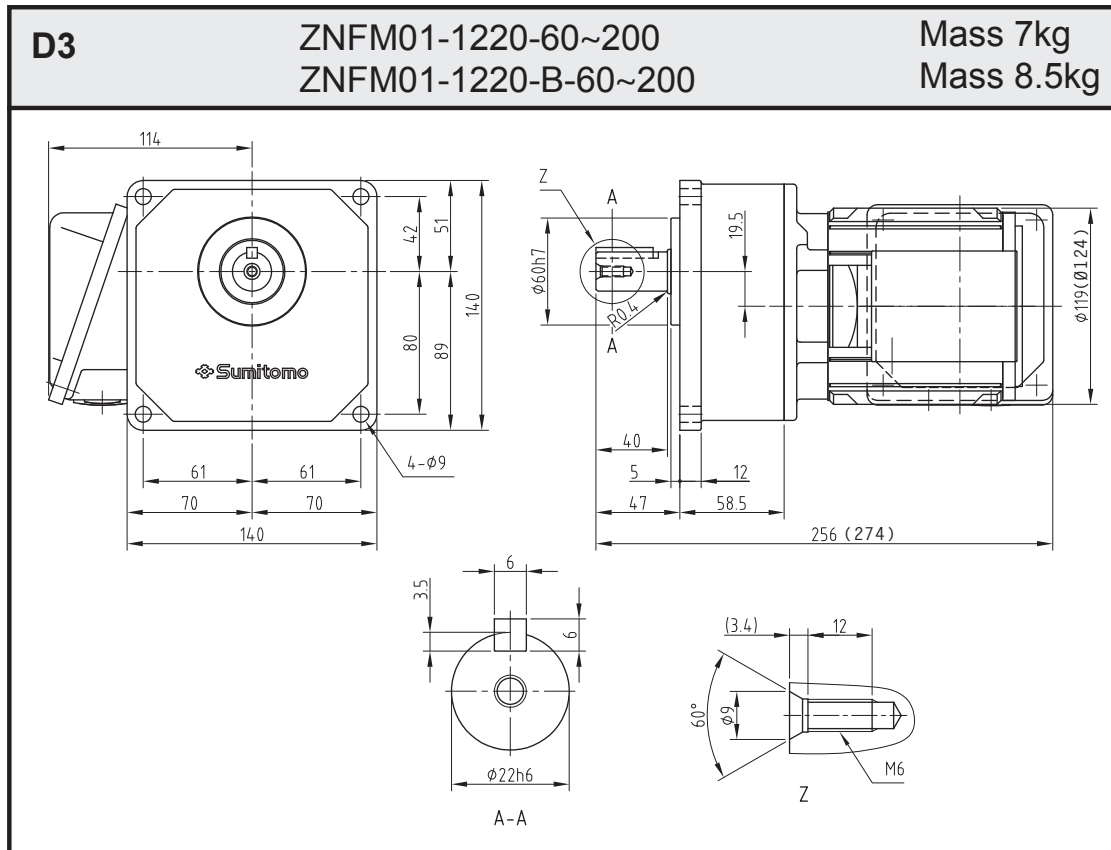

- Note)
1. Output shaft diameter: Dimension tolerance compliant with the JIS B 0401-1998 "h6."
 2. Shaft end key dimensions: Dimension tolerance compliant with the JIS B 1301-1996 "Parallel Keys."
 3. For the detailed dimensions of the output shaft section, see Page 33 of Technical Information.
 4. The dimensions and masses in the dimensions drawings are subject to change without prior notice.
 5. Values in parentheses indicate the type, dimensions and mass of the motor with brake.

10.0 Dimension Drawings

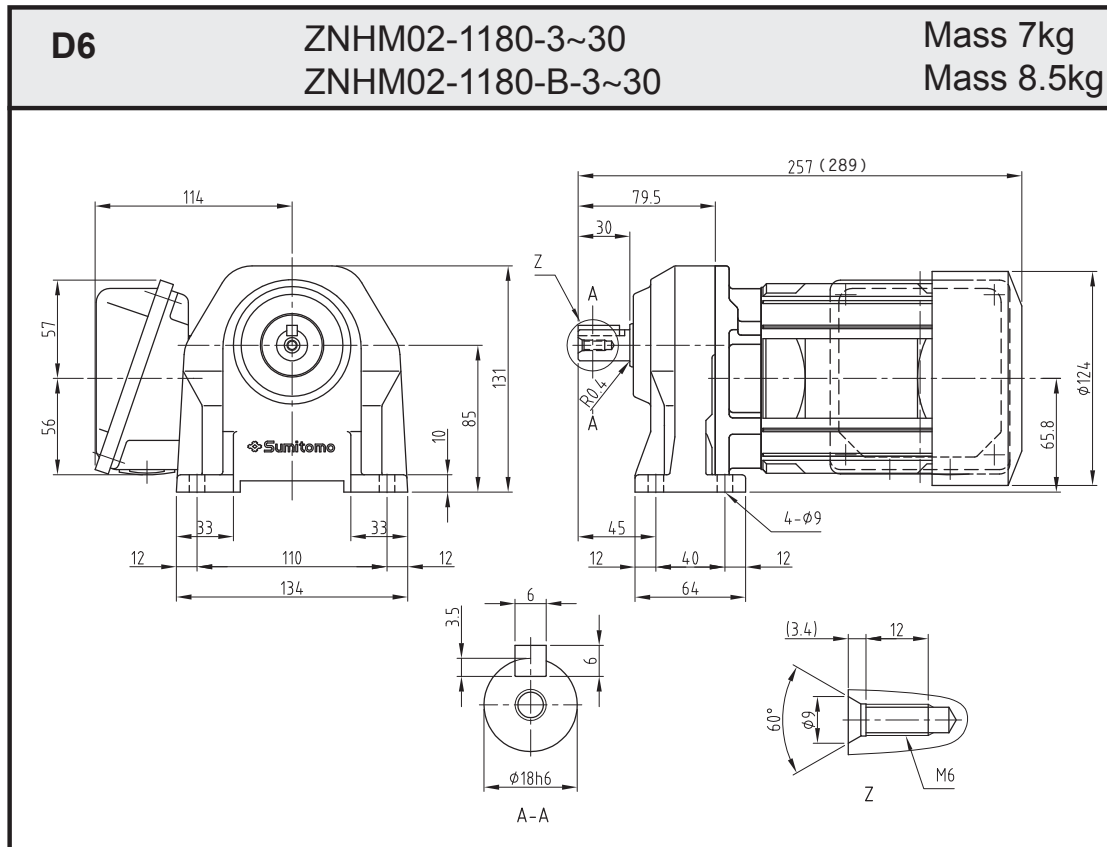
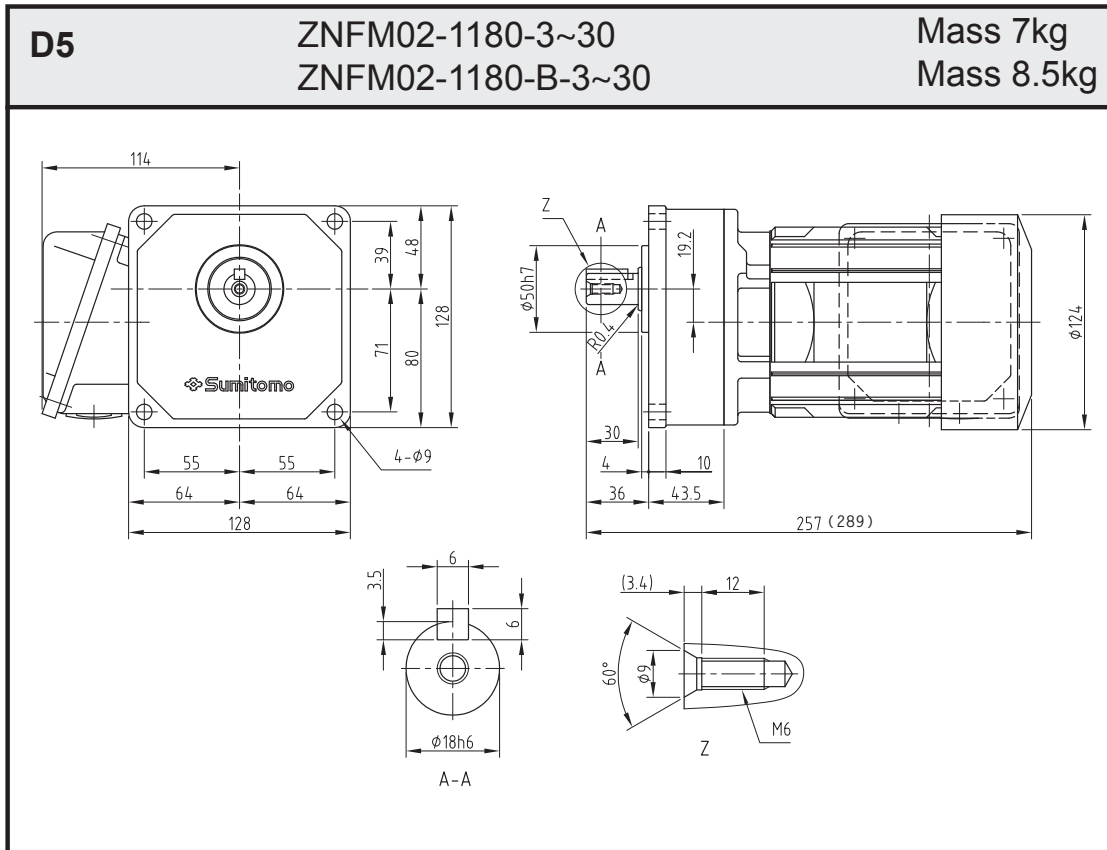

- Note) 1. Output shaft diameter: Dimension tolerance compliant with the JIS B 0401-1998 "h6."
 2. Shaft end key dimensions: Dimension tolerance compliant with the JIS B 1301-1996 "Parallel Keys."
 3. For the detailed dimensions of the output shaft section, see Page 33 of Technical Information.
 4. The dimensions and masses in the dimensions drawings are subject to change without prior notice.
 5. Values in parentheses indicate the type, dimensions and mass of the motor with brake.

10.0 Dimension Drawings

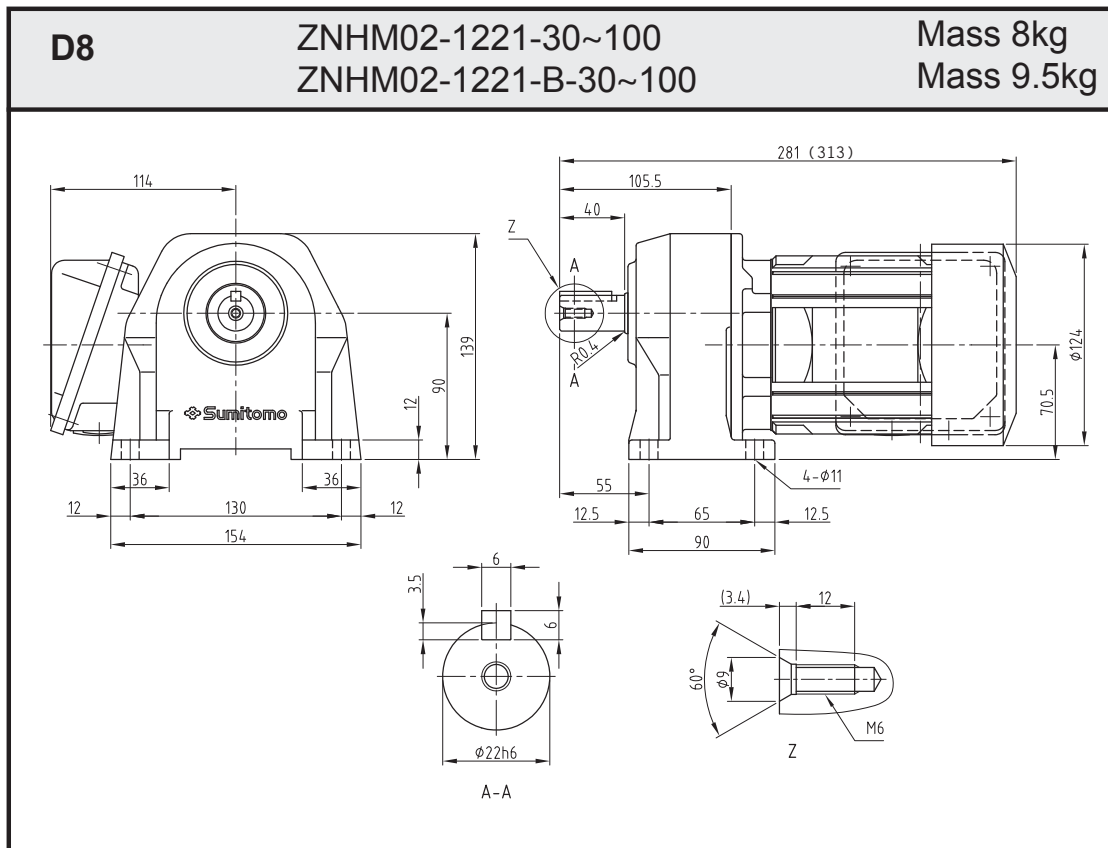
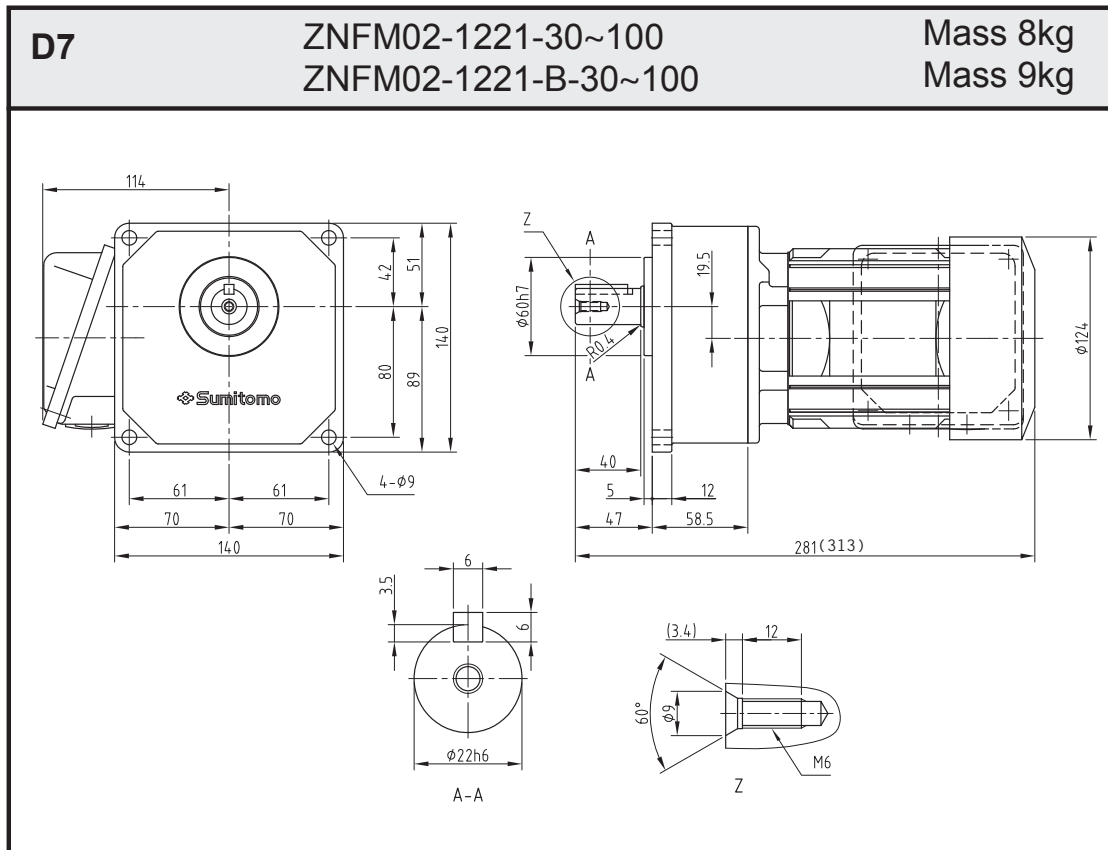

- Note) 1. Output shaft diameter: Dimension tolerance compliant with the JIS B 0401-1998 "h6."
 2. Shaft end key dimensions: Dimension tolerance compliant with the JIS B 1301-1996 "Parallel Keys."
 3. For the detailed dimensions of the output shaft section, see Page 33 of Technical Information.
 4. The dimensions and masses in the dimensions drawings are subject to change without prior notice.
 5. Values in parentheses indicate the type, dimensions and mass of the motor with brake.

10.0 Dimension Drawings

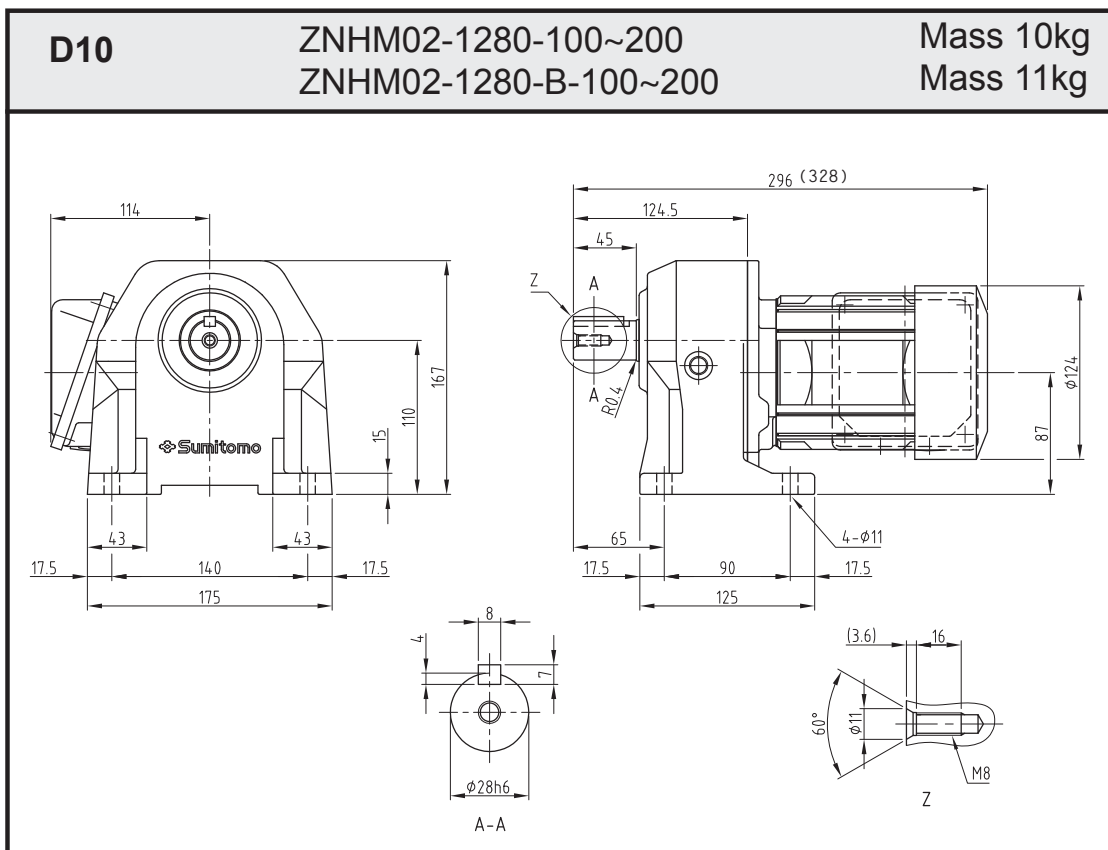
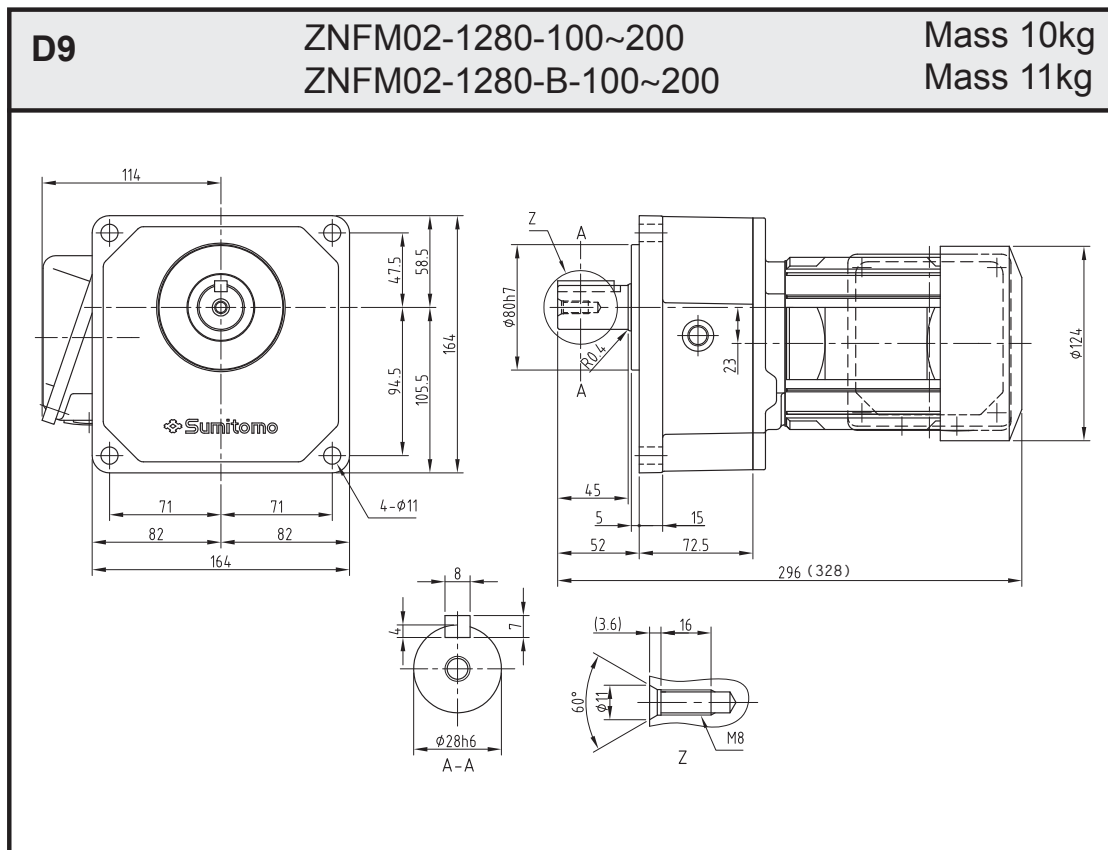

- Note)
1. Output shaft diameter: Dimension tolerance compliant with the JIS B 0401-1998 "h6."
 2. Shaft end key dimensions: Dimension tolerance compliant with the JIS B 1301-1996 "Parallel Keys."
 3. For the detailed dimensions of the output shaft section, see Page 33 of Technical Information.
 4. The dimensions and masses in the dimensions drawings are subject to change without prior notice.
 5. Values in parentheses indicate the type, dimensions and mass of the motor with brake.

10.0 Dimension Drawings

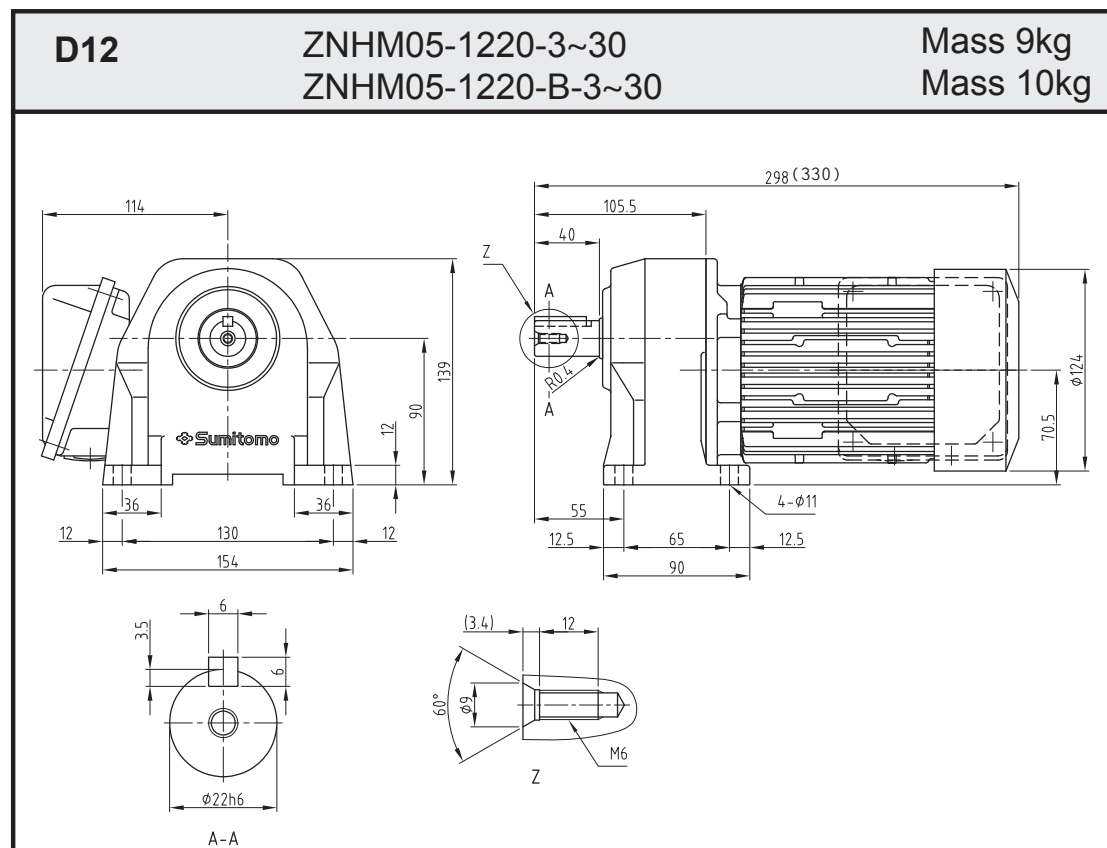
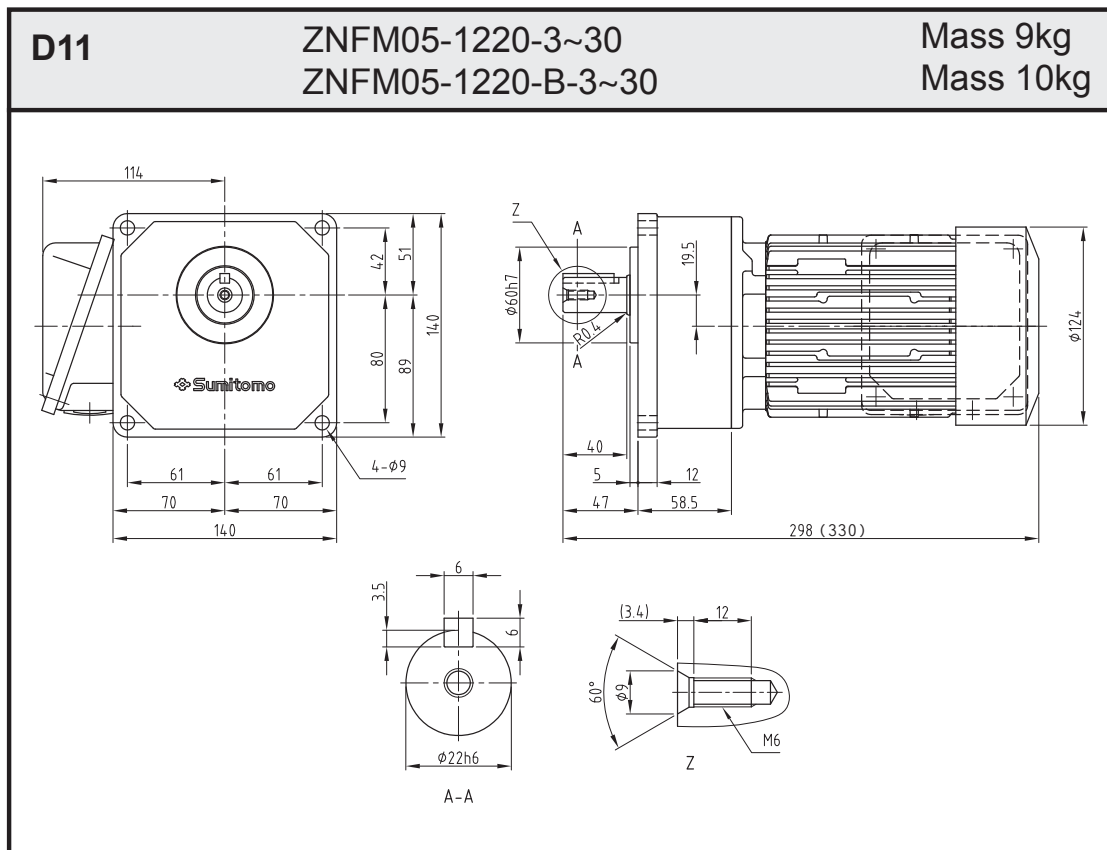

- Note)
1. Output shaft diameter: Dimension tolerance compliant with the JIS B 0401-1998 "h6."
 2. Shaft end key dimensions: Dimension tolerance compliant with the JIS B 1301-1996 "Parallel Keys."
 3. For the detailed dimensions of the output shaft section, see Page 33 of Technical Information.
 4. The dimensions and masses in the dimensions drawings are subject to change without prior notice.
 5. Values in parentheses indicate the type, dimensions and mass of the motor with brake.

10.0 Dimension Drawings

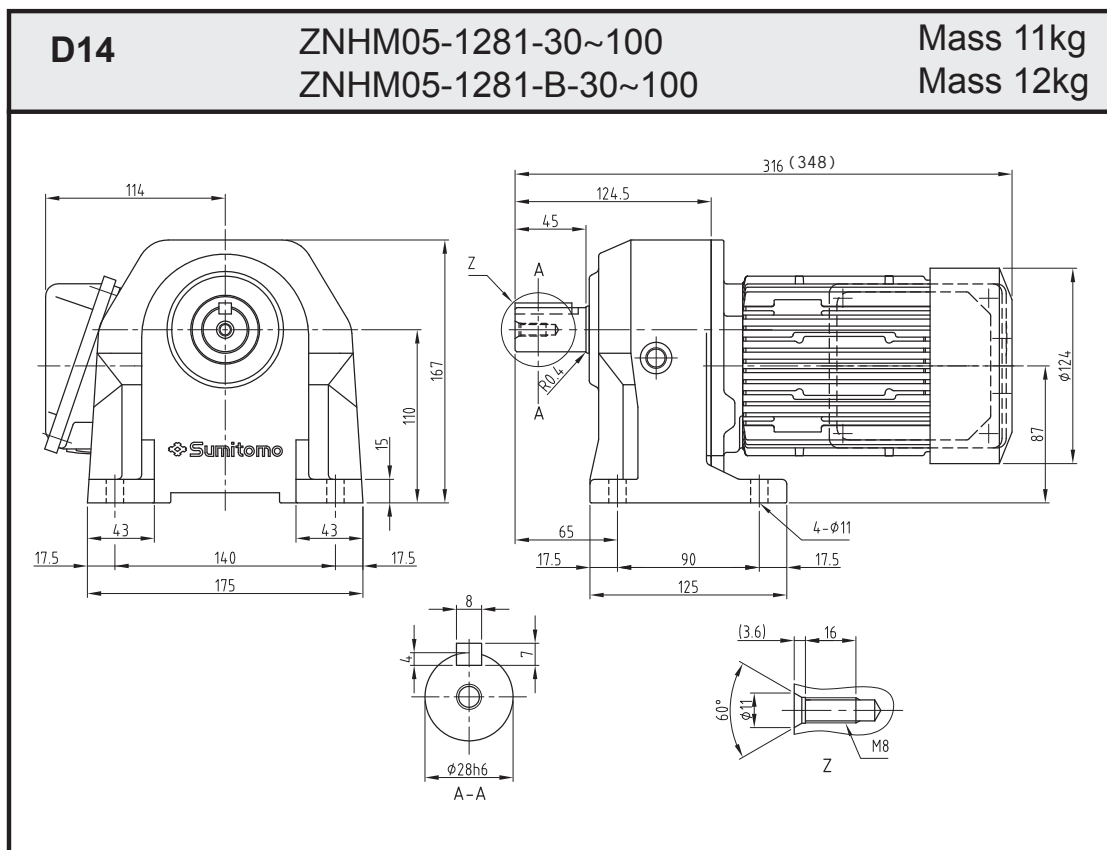
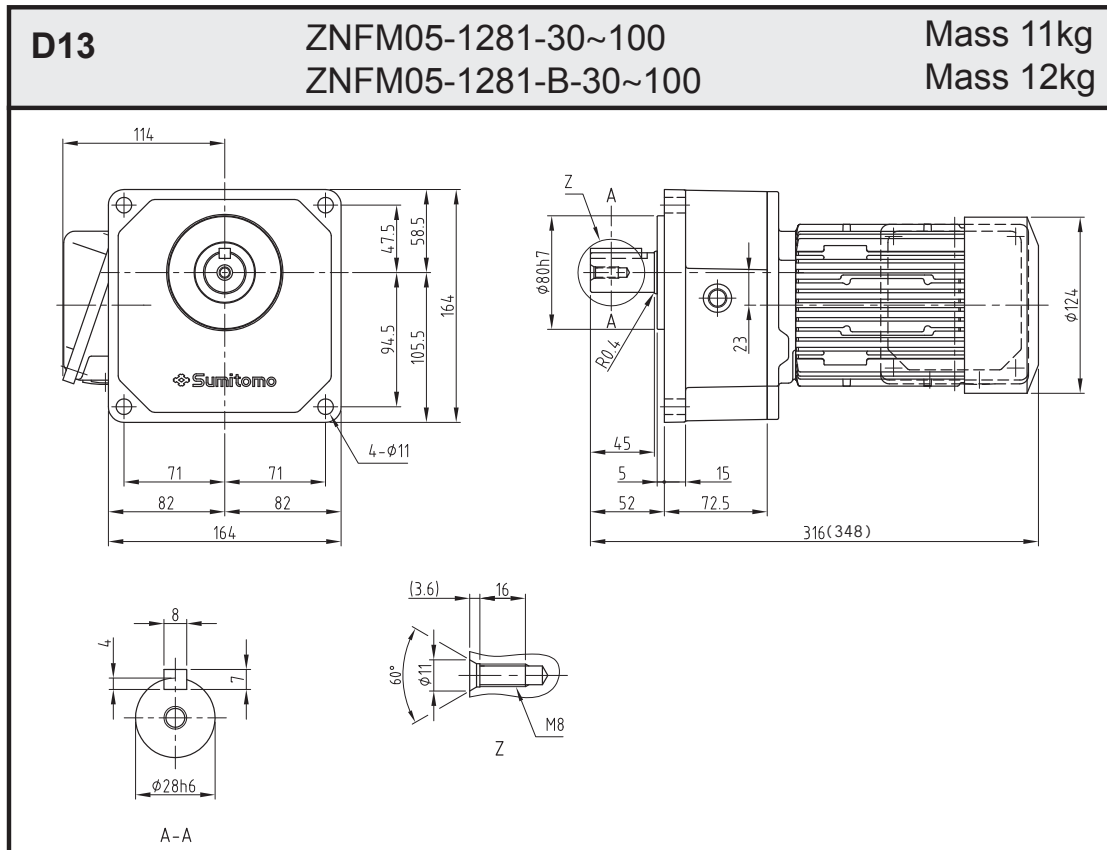

- Note)
1. Output shaft diameter: Dimension tolerance compliant with the JIS B 0401-1998 "h6."
 2. Shaft end key dimensions: Dimension tolerance compliant with the JIS B 1301-1996 "Parallel Keys."
 3. For the detailed dimensions of the output shaft section, see Page 33 of Technical Information.
 4. The dimensions and masses in the dimensions drawings are subject to change without prior notice.
 5. Values in parentheses indicate the type, dimensions and mass of the motor with brake.

10.0 Dimension Drawings

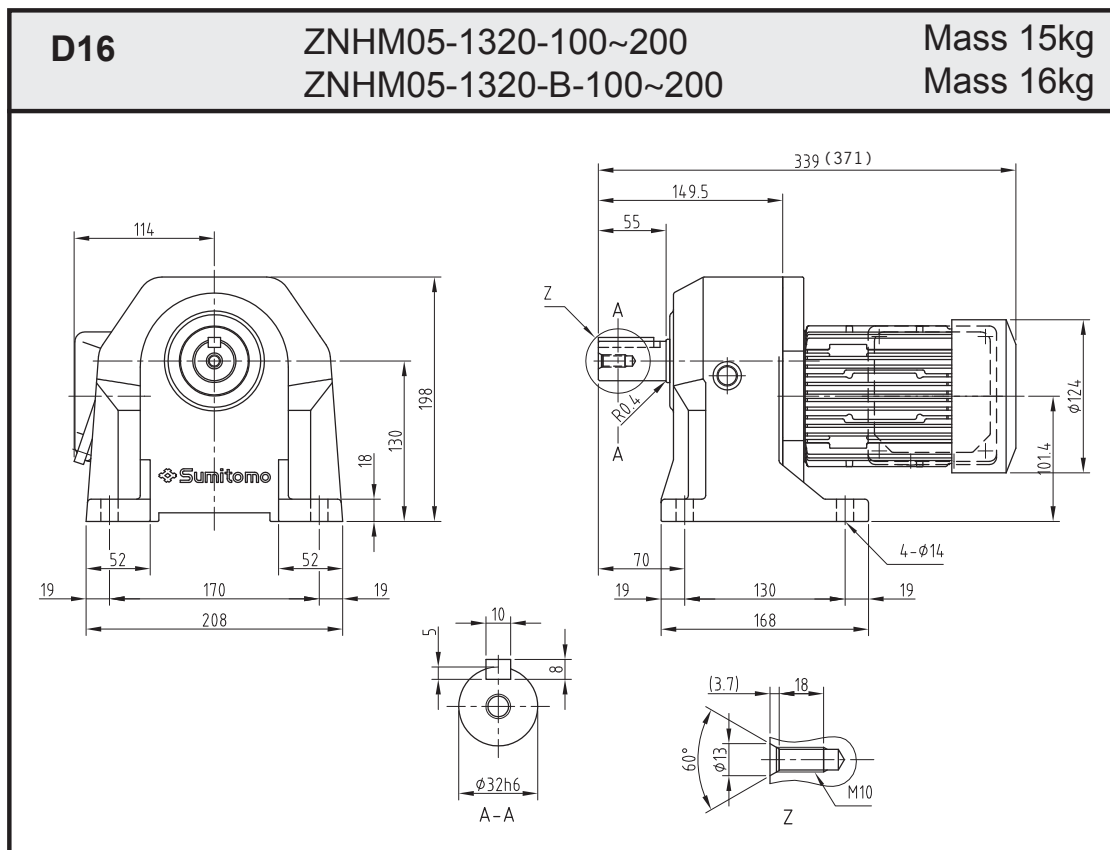
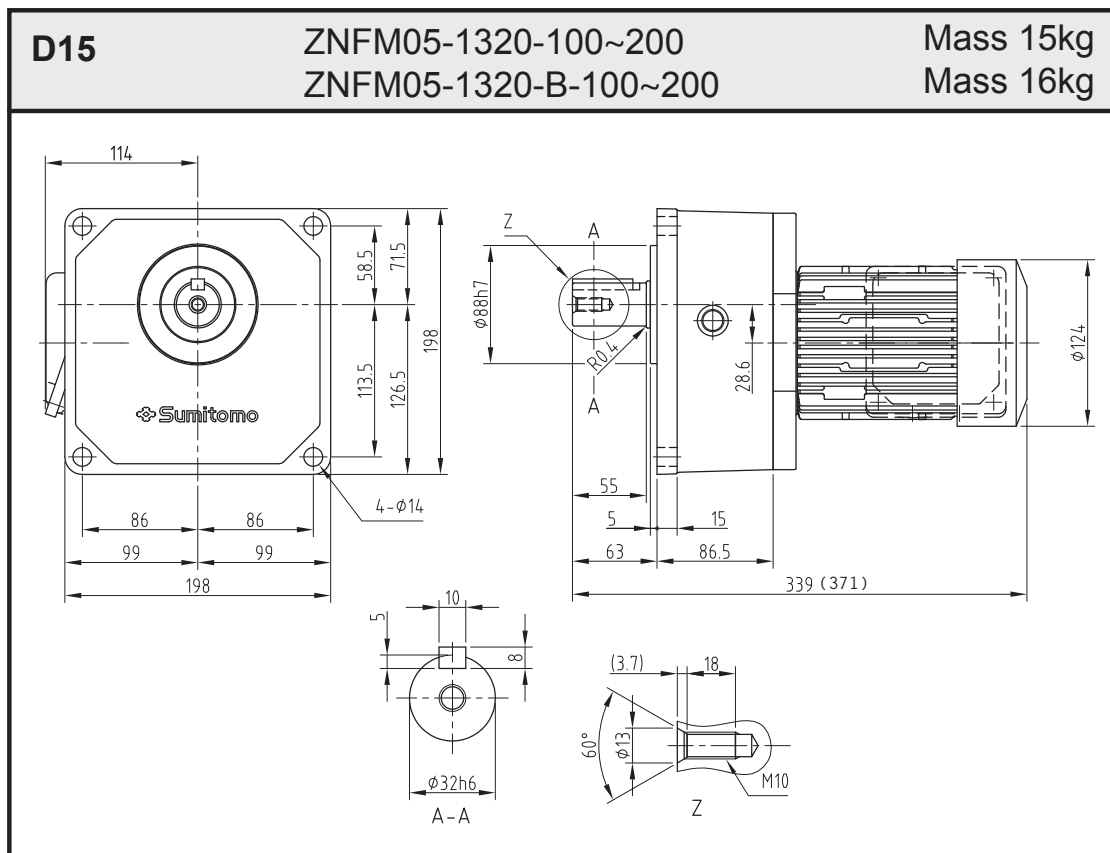

- Note)
1. Output shaft diameter: Dimension tolerance compliant with the JIS B 0401-1998 "h6."
 2. Shaft end key dimensions: Dimension tolerance compliant with the JIS B 1301-1996 "Parallel Keys."
 3. For the detailed dimensions of the output shaft section, see Page 33 of Technical Information.
 4. The dimensions and masses in the dimensions drawings are subject to change without prior notice.
 5. Values in parentheses indicate the type, dimensions and mass of the motor with brake.

10.0 Dimension Drawings

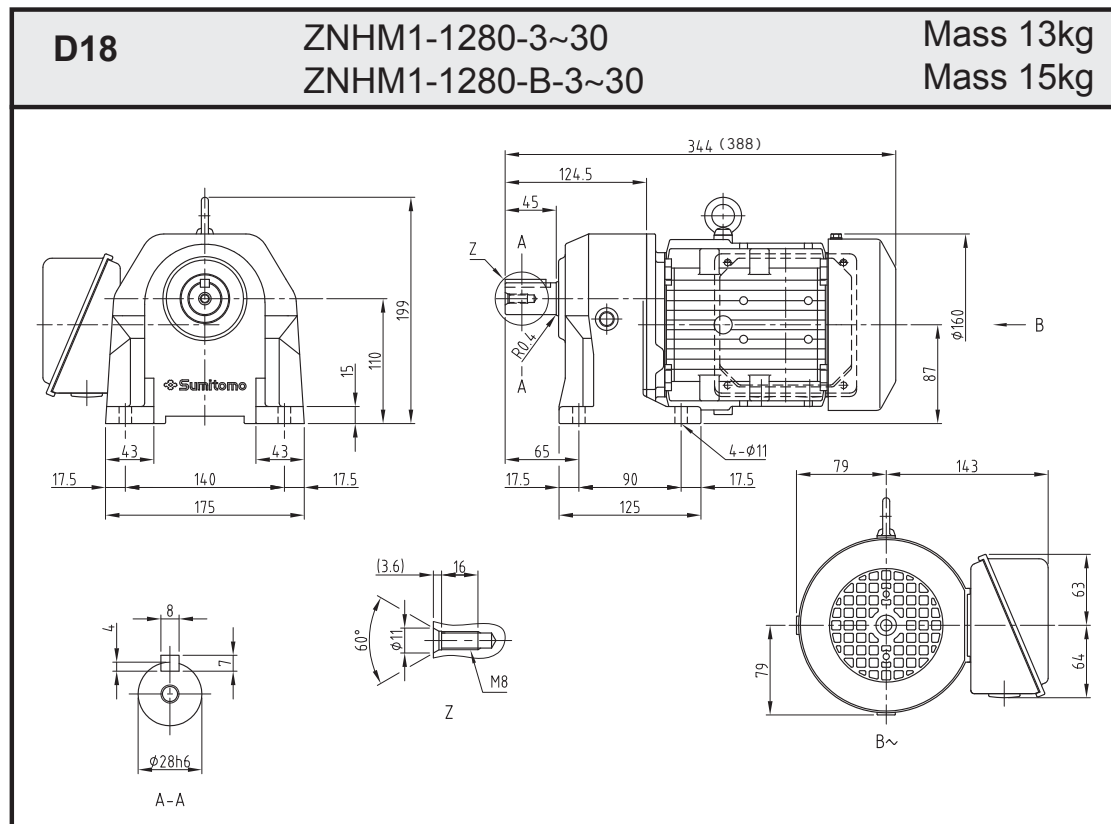
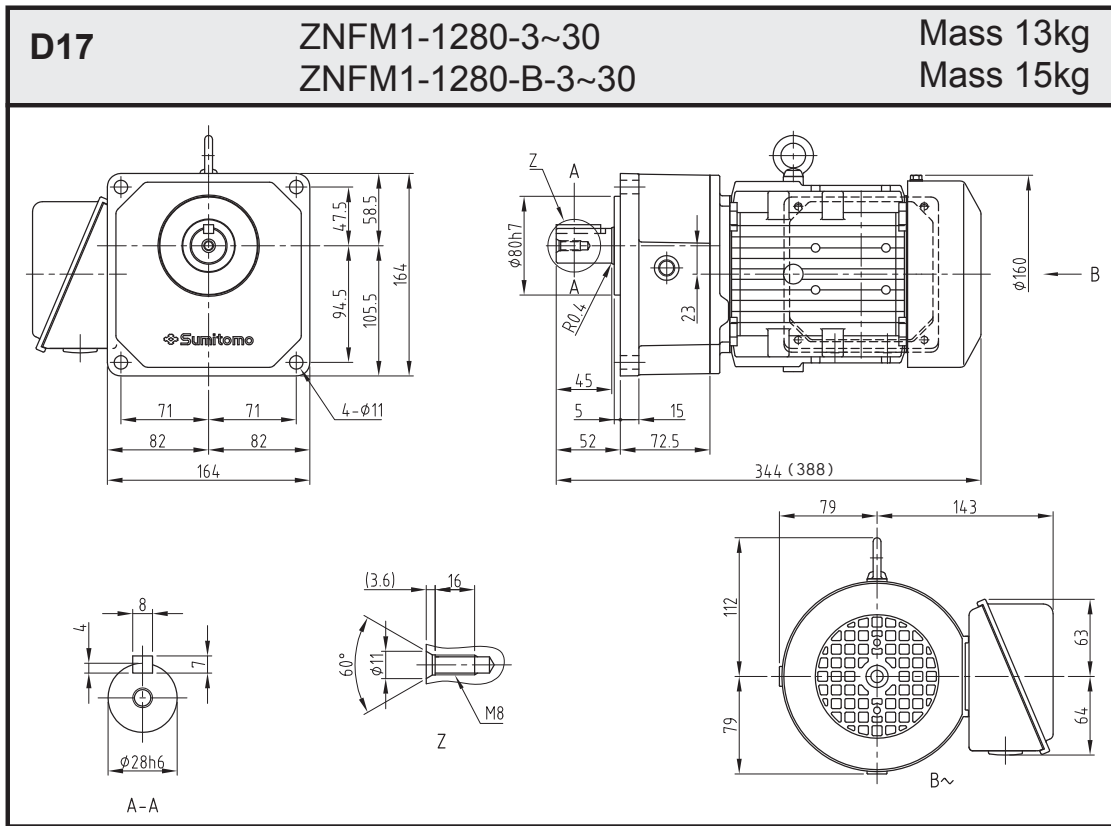

- Note) 1. Output shaft diameter: Dimension tolerance compliant with the JIS B 0401-1998 "h6."
 2. Shaft end key dimensions: Dimension tolerance compliant with the JIS B 1301-1996 "Parallel Keys."
 3. For the detailed dimensions of the output shaft section, see Page 33 of Technical Information.
 4. The dimensions and masses in the dimensions drawings are subject to change without prior notice.
 5. Values in parentheses indicate the type, dimensions and mass of the motor with brake.

10.0 Dimension Drawings

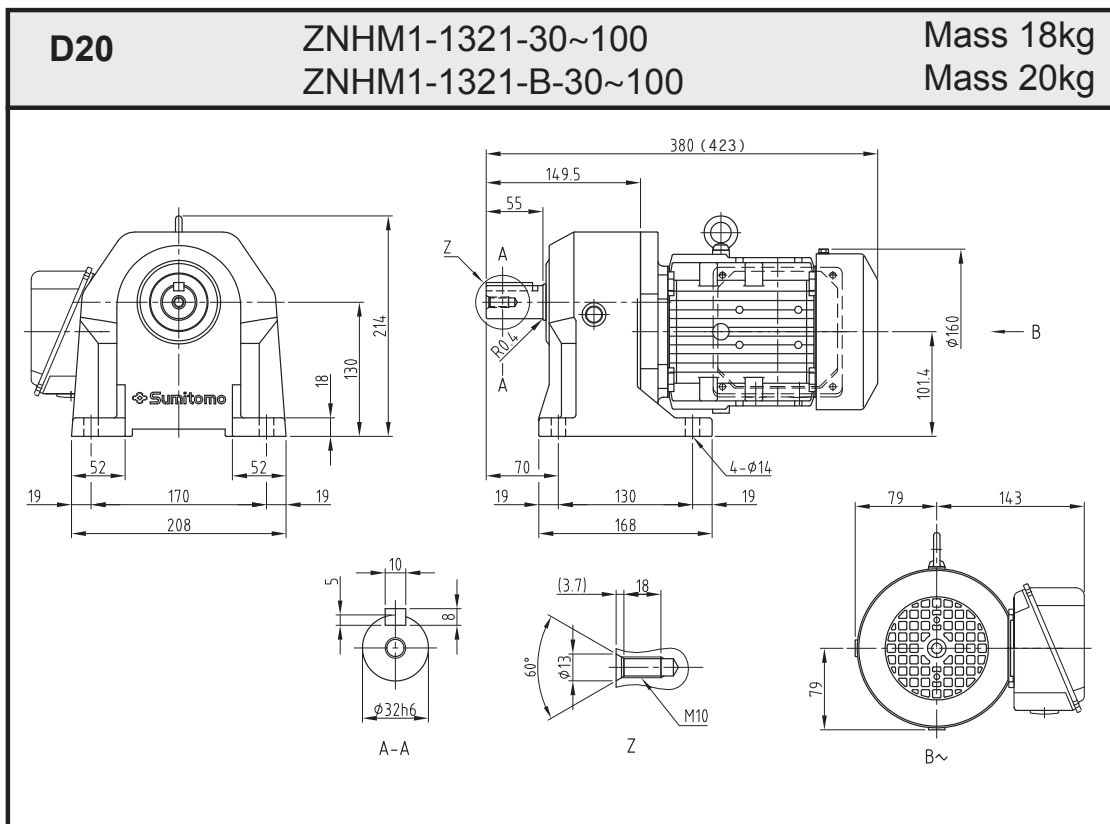
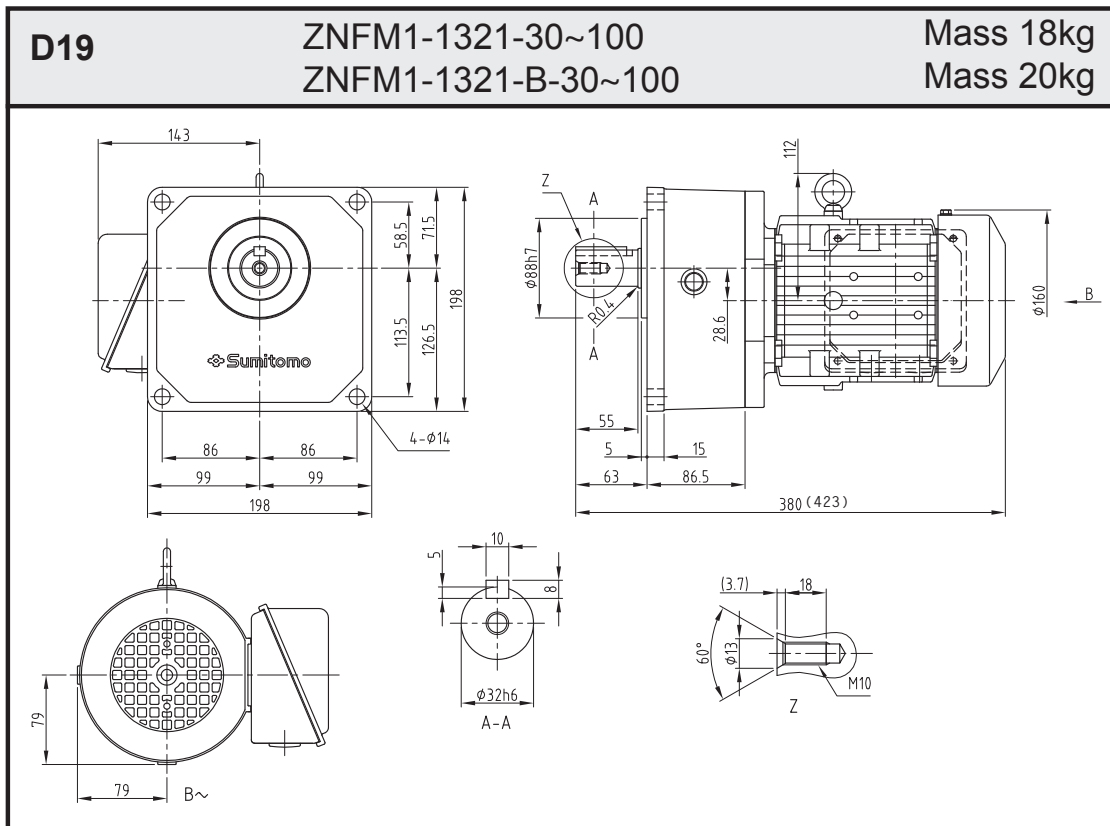

- Note)
1. Output shaft diameter: Dimension tolerance compliant with the JIS B 0401-1998 "h6."
 2. Shaft end key dimensions: Dimension tolerance compliant with the JIS B 1301-1996 "Parallel Keys."
 3. For the detailed dimensions of the output shaft section, see Page 33 of Technical Information.
 4. The dimensions and masses in the dimensions drawings are subject to change without prior notice.
 5. Values in parentheses indicate the type, dimensions and mass of the motor with brake.

10.0 Dimension Drawings

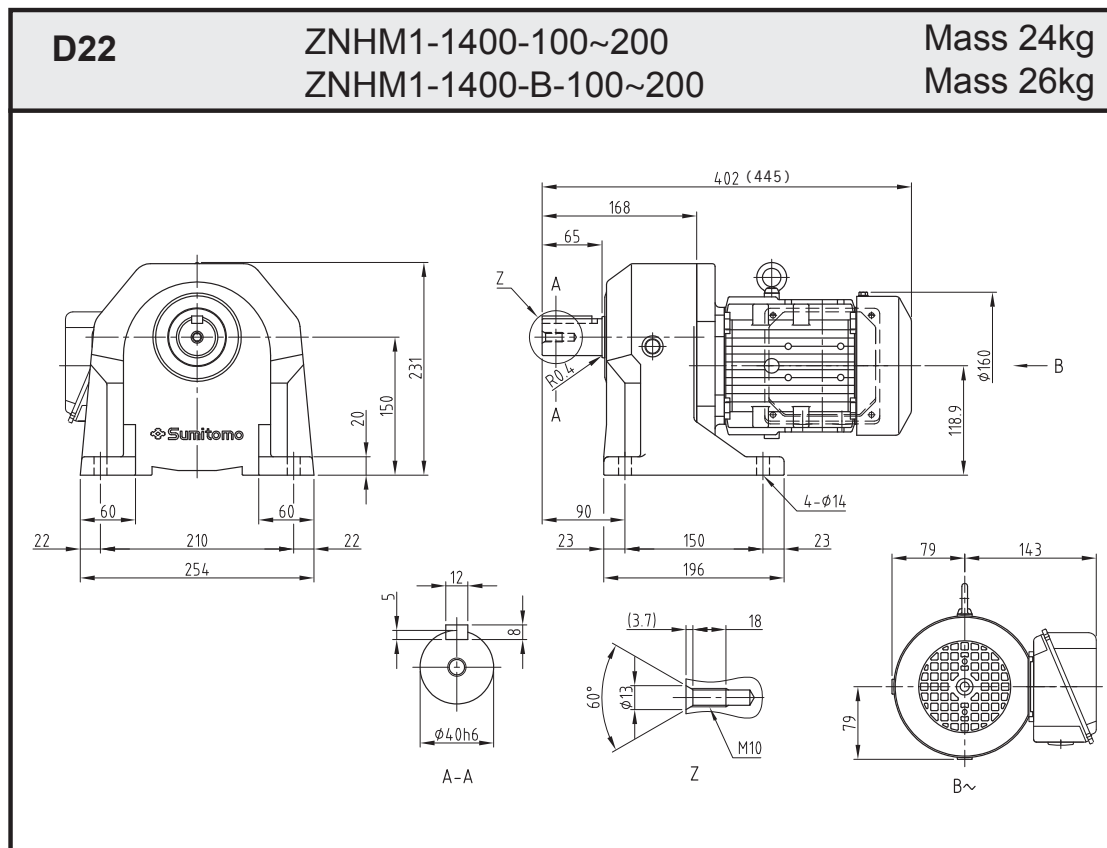
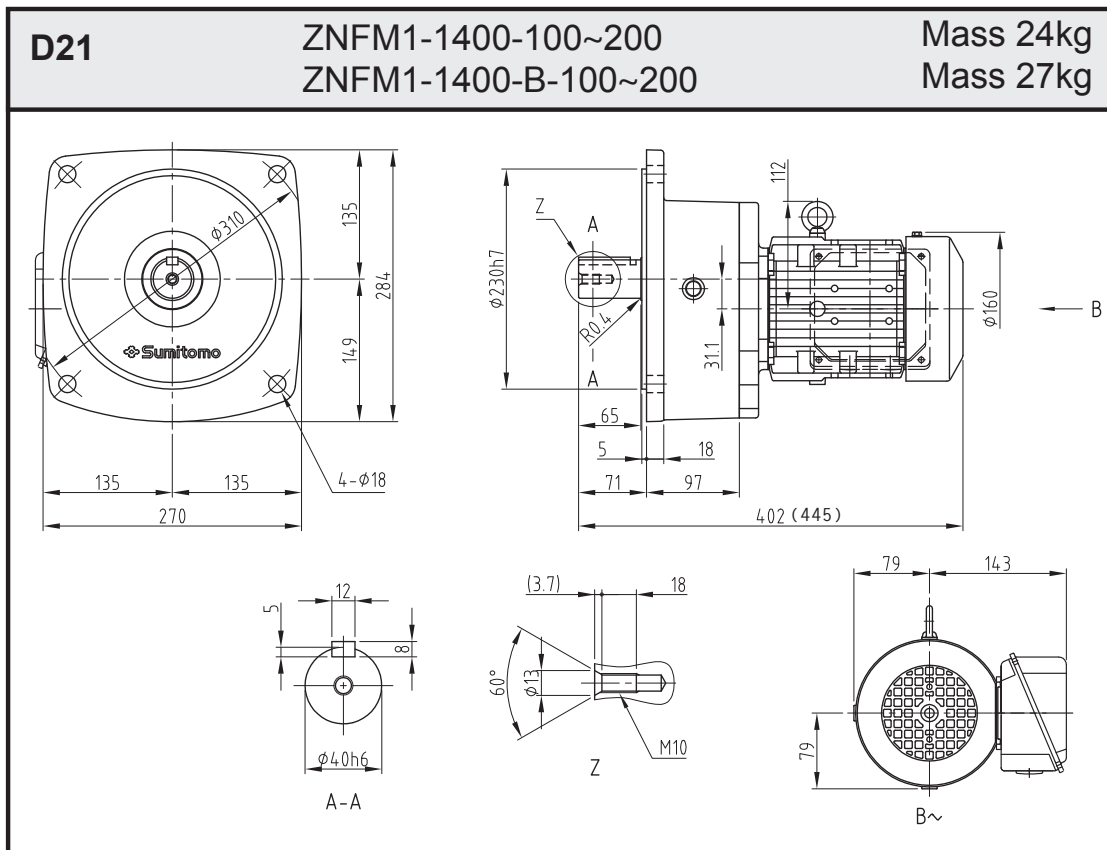

- Note)
1. Output shaft diameter: Dimension tolerance compliant with the JIS B 0401-1998 "h6."
 2. Shaft end key dimensions: Dimension tolerance compliant with the JIS B 1301-1996 "Parallel Keys."
 3. For the detailed dimensions of the output shaft section, see Page 33 of Technical Information.
 4. The dimensions and masses in the dimensions drawings are subject to change without prior notice.
 5. Values in parentheses indicate the type, dimensions and mass of the motor with brake.

10.0 Dimension Drawings

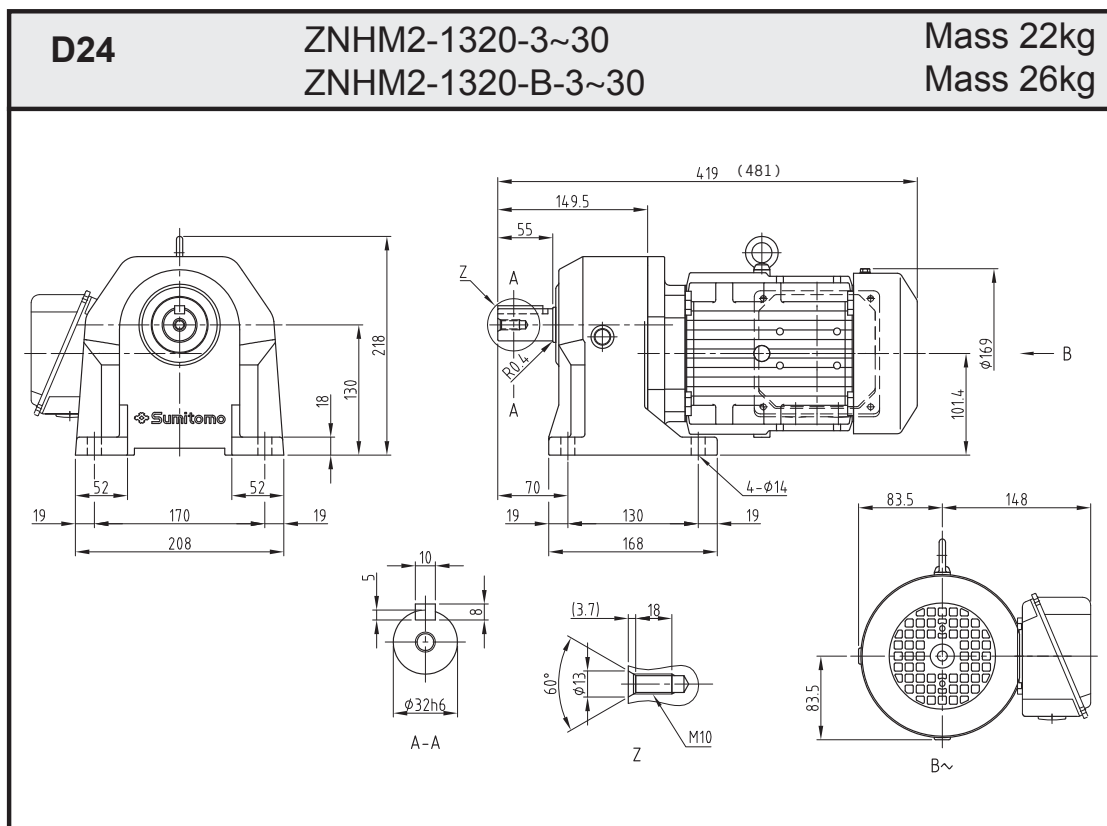
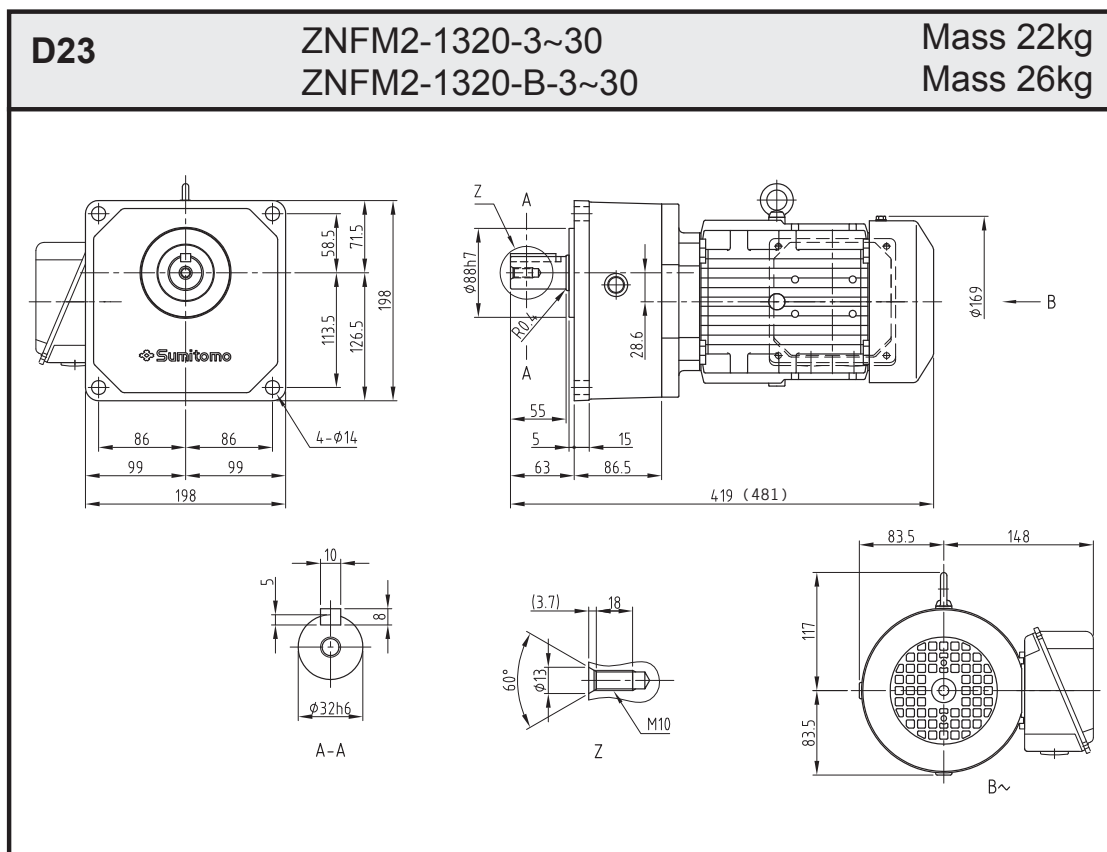

- Note)
1. Output shaft diameter: Dimension tolerance compliant with the JIS B 0401-1998 "h6."
 2. Shaft end key dimensions: Dimension tolerance compliant with the JIS B 1301-1996 "Parallel Keys."
 3. For the detailed dimensions of the output shaft section, see Page 33 of Technical Information.
 4. The dimensions and masses in the dimensions drawings are subject to change without prior notice.
 5. Values in parentheses indicate the type, dimensions and mass of the motor with brake.

10.0 Dimension Drawings

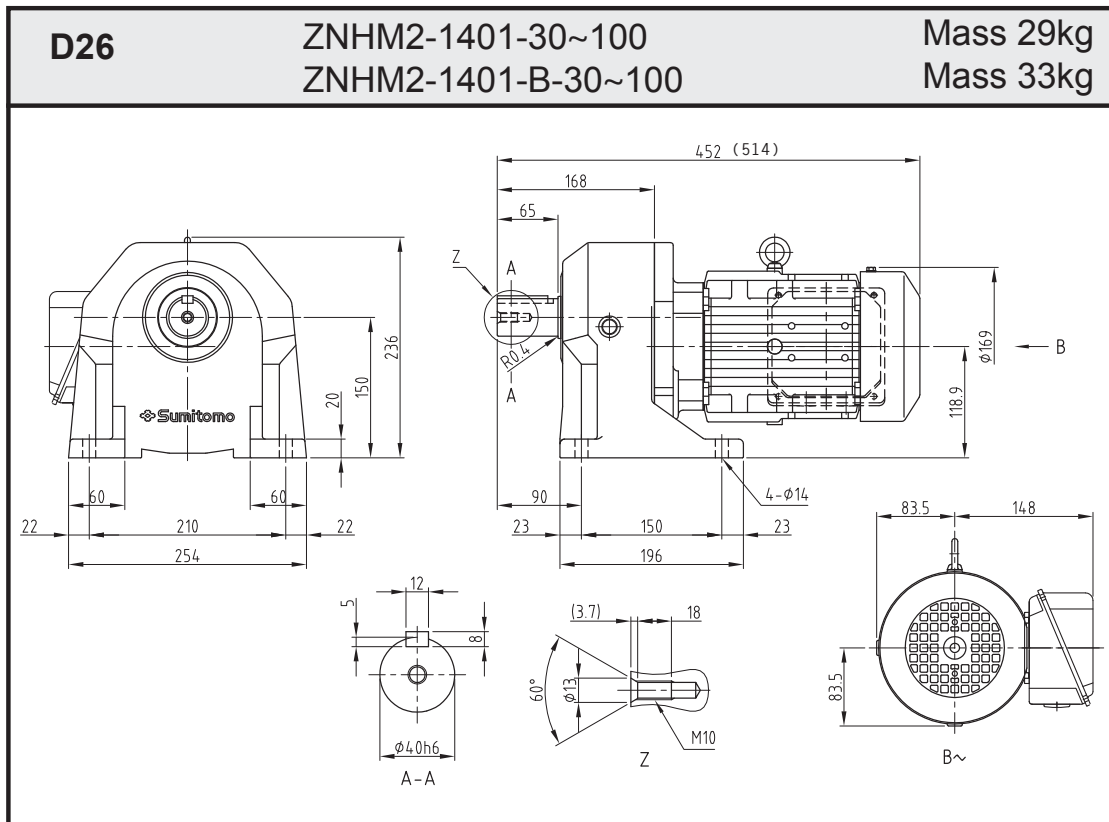
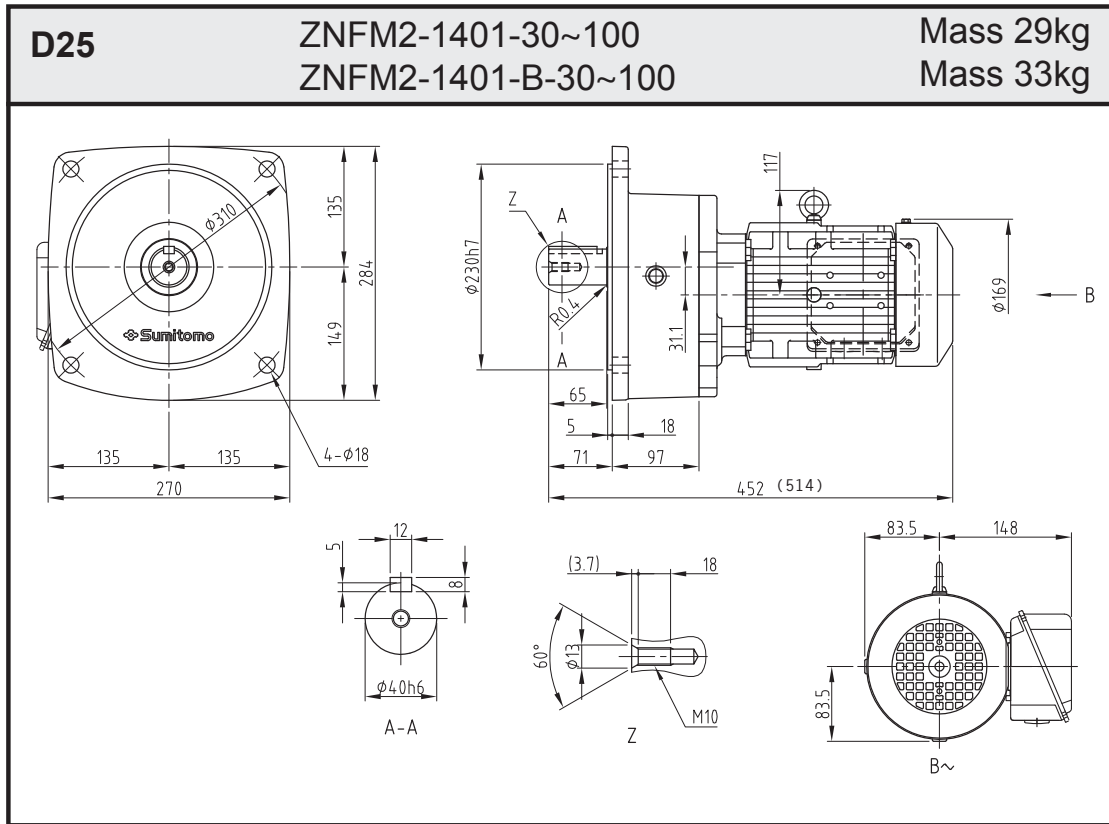

- Note) 1. Output shaft diameter: Dimension tolerance compliant with the JIS B 0401-1998 "h6."
 2. Shaft end key dimensions: Dimension tolerance compliant with the JIS B 1301-1996 "Parallel Keys."
 3. For the detailed dimensions of the output shaft section, see Page 33 of Technical Information.
 4. The dimensions and masses in the dimensions drawings are subject to change without prior notice.
 5. Values in parentheses indicate the type, dimensions and mass of the motor with brake.

10.0 Dimension Drawings

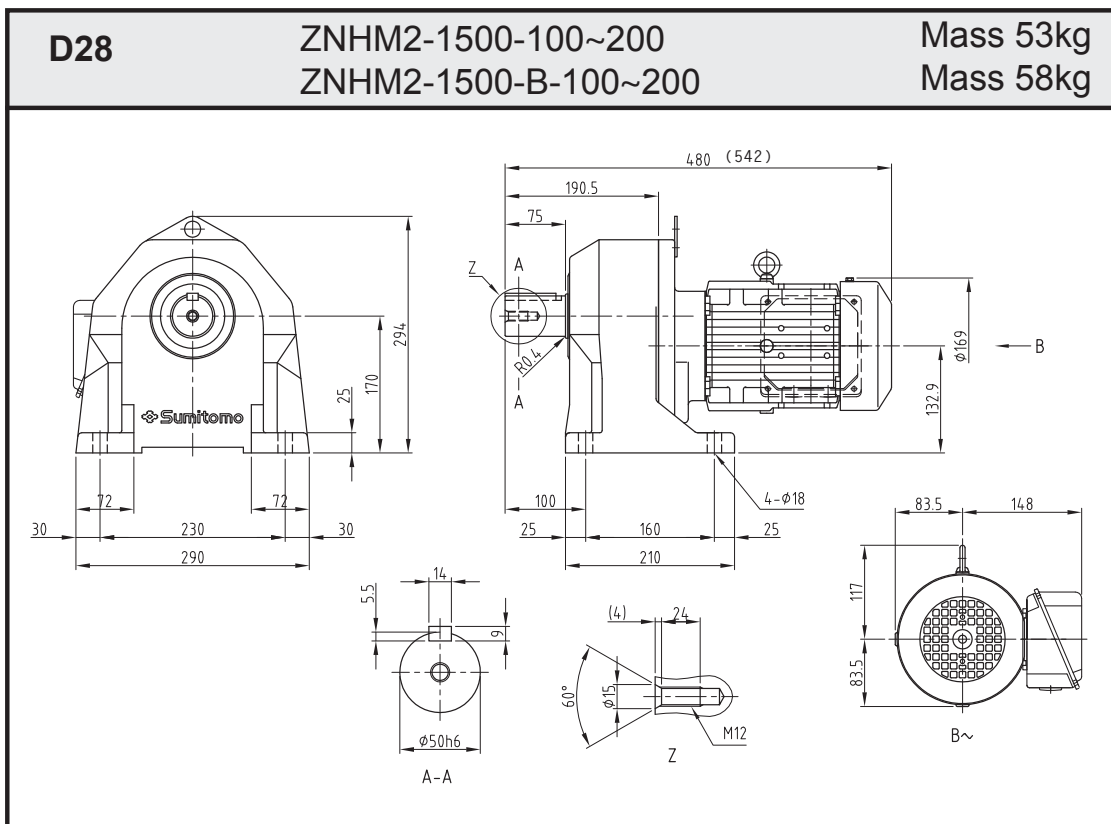
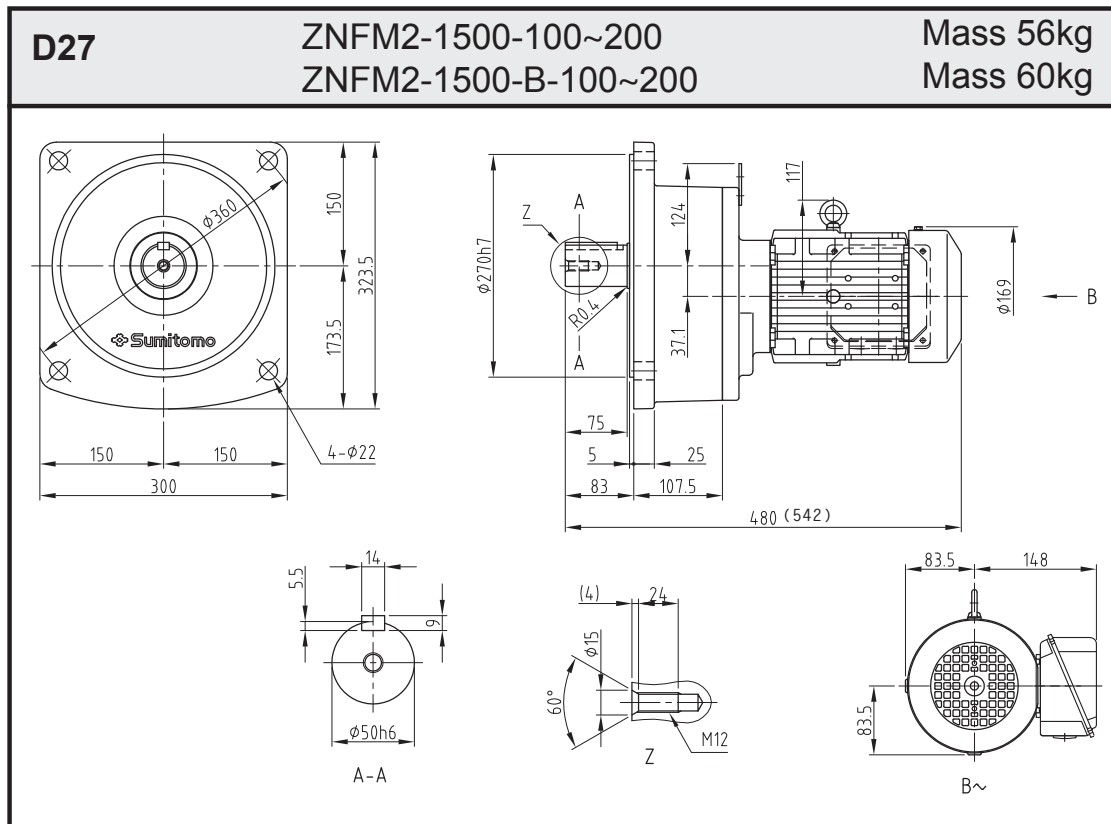

- Note)
1. Output shaft diameter: Dimension tolerance compliant with the JIS B 0401-1998 "h6."
 2. Shaft end key dimensions: Dimension tolerance compliant with the JIS B 1301-1996 "Parallel Keys."
 3. For the detailed dimensions of the output shaft section, see Page 33 of Technical Information.
 4. The dimensions and masses in the dimensions drawings are subject to change without prior notice.
 5. Values in parentheses indicate the type, dimensions and mass of the motor with brake.

10.0 Dimension Drawings

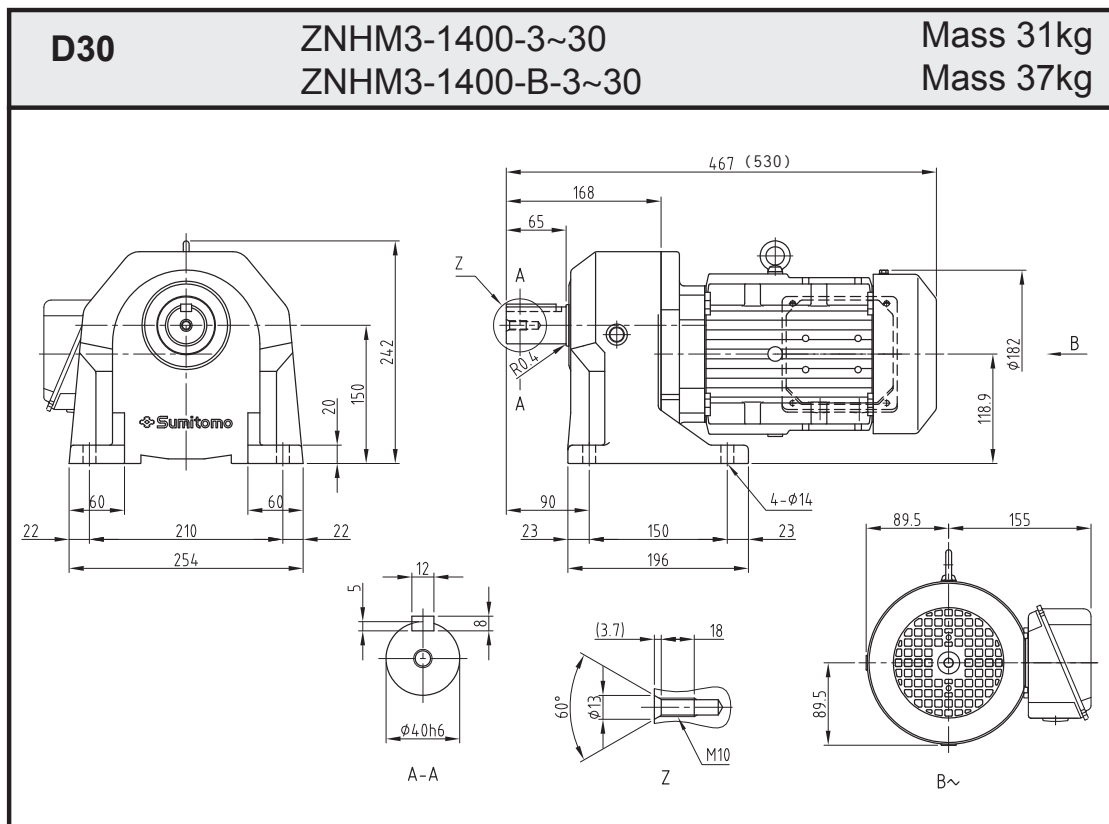
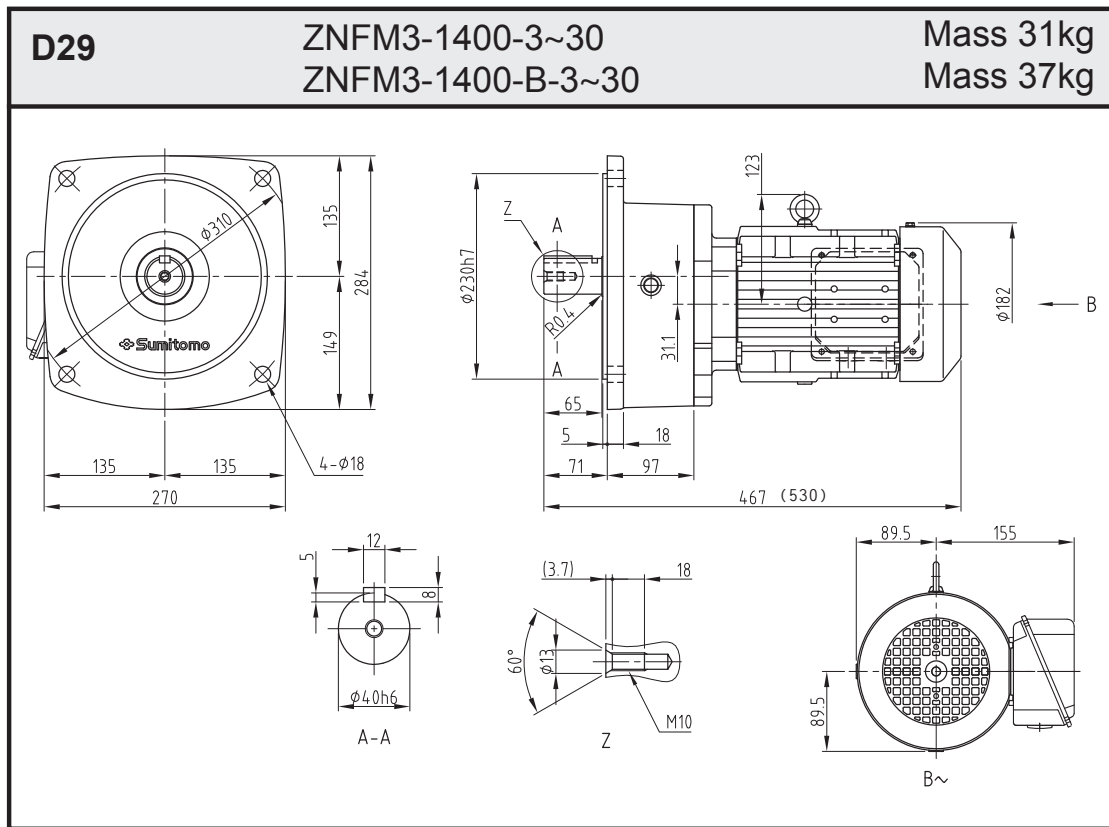

- Note)
1. Output shaft diameter: Dimension tolerance compliant with the JIS B 0401-1998 "h6."
 2. Shaft end key dimensions: Dimension tolerance compliant with the JIS B 1301-1996 "Parallel Keys."
 3. For the detailed dimensions of the output shaft section, see Page 33 of Technical Information.
 4. The dimensions and masses in the dimensions drawings are subject to change without prior notice.
 5. Values in parentheses indicate the type, dimensions and mass of the motor with brake.

10.0 Dimension Drawings

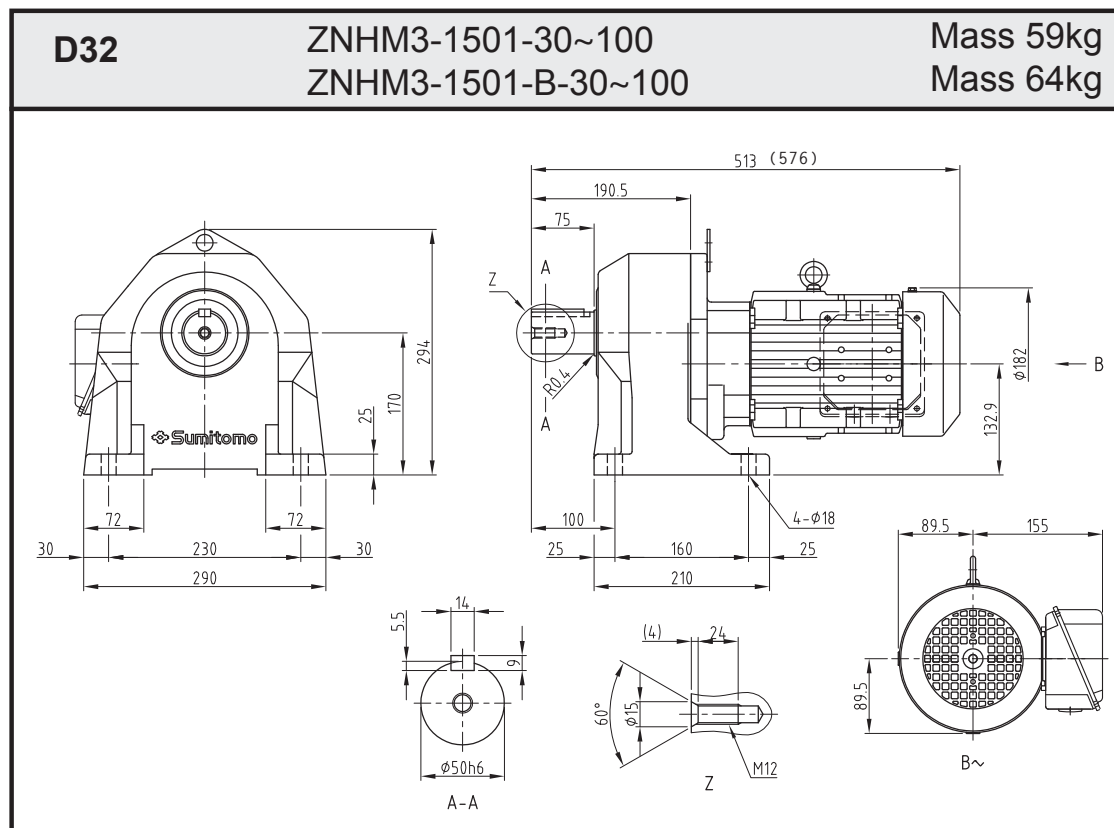
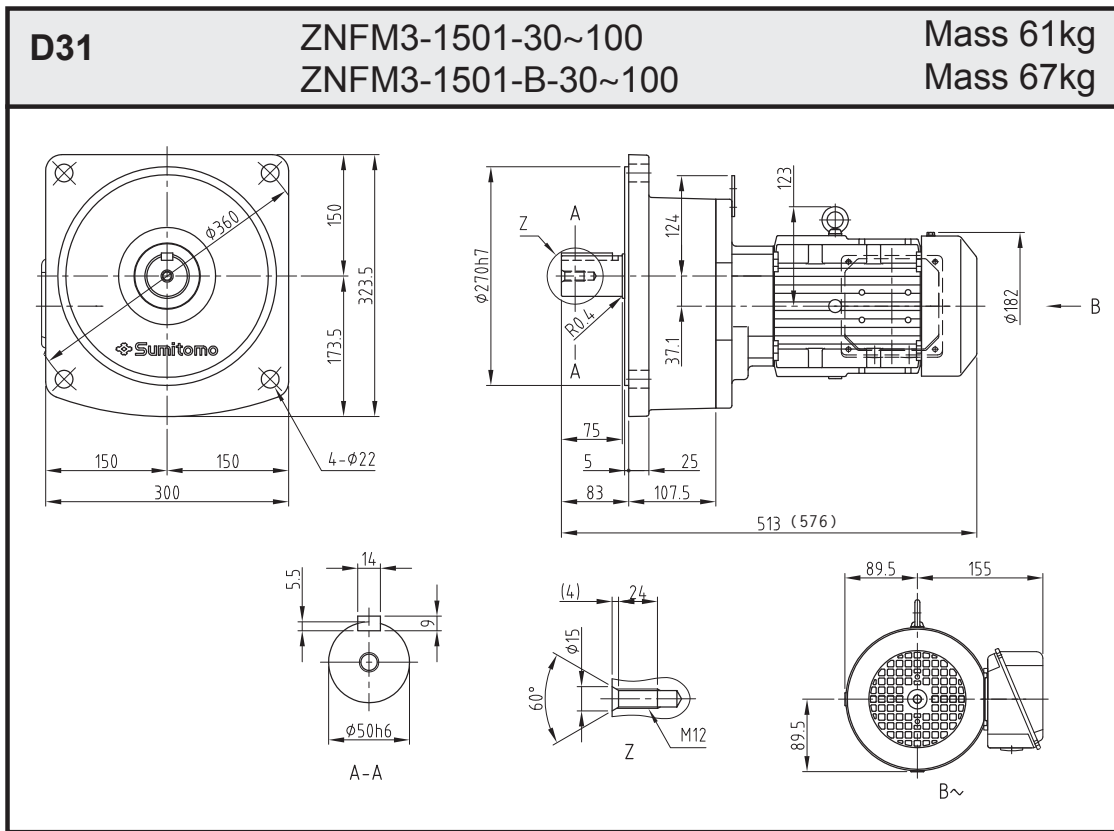

- Note)
1. Output shaft diameter: Dimension tolerance compliant with the JIS B 0401-1998 "h6."
 2. Shaft end key dimensions: Dimension tolerance compliant with the JIS B 1301-1996 "Parallel Keys."
 3. For the detailed dimensions of the output shaft section, see Page 33 of Technical Information.
 4. The dimensions and masses in the dimensions drawings are subject to change without prior notice.
 5. Values in parentheses indicate the type, dimensions and mass of the motor with brake.

11.0 Technical Information: Gear Unit

11.1 Output Shaft Allowable Thrust Load

$$\left(\frac{Pr \cdot Lf}{Pro} + \frac{Pa}{Pao} \right) \cdot Cf \cdot Fs \leq 1$$

Select each value to ensure the following formula.

- Pr : Actual radial load
- Pro : Allowable radial load (see a selection table)
- Pa : Actual thrust load
- Pao : Allowable thrust load
- Lf : Load location factor (Page 7, Table 2)
- Cf : Coupling factor (Page 7, Table 3)
- Fs : Shock factor (Page 7, Table 4)

Table 10 Output Shaft Allowable Thrust Loads

Frame No.	Unit	Reduction ratio															
		3	5	10	15	20	25	30	40	50	60	80	100	120	150	200	
1180	N	230	270	350	410	470	500	540	600	620	-	-	-	-	-	-	
	kgf	23	27	36	42	48	51	55	61	64	-	-	-	-	-	-	
1220	N	230	350	470	540	610	660	700	-	-	890	970	970	970	970	970	
	kgf	23	36	48	55	62	68	71	-	-	91	99	99	99	99	99	
1221	N	-	-	-	-	-	-	700	760	830	890	970	970	-	-	-	
	kgf	-	-	-	-	-	-	71	78	84	91	99	99	-	-	-	
1280	N	170	330	700	860	930	970	981	-	-	-	-	981	981	981	981	
	kgf	17	34	71	87	95	99	100	-	-	-	-	100	100	100	100	
1281	N	-	-	-	-	-	-	981	981	981	981	981	981	-	-	-	
	kgf	-	-	-	-	-	-	100	100	100	100	100	100	-	-	-	
1320	N	280	580	970	1160	1350	1470	1470	-	-	-	-	1470	1470	1470	1470	
	kgf	29	59	99	118	138	150	150	-	-	-	-	150	150	150	150	
1321	N	-	-	-	-	-	-	1470	1470	1470	1470	1470	1470	-	-	-	
	kgf	-	-	-	-	-	-	150	150	150	150	150	150	-	-	-	
1400	N	300	600	1240	1490	1670	1860	2020	-	-	-	-	2800	2800	2800	2800	
	kgf	30	61	127	151	171	190	206	-	-	-	-	285	285	285	285	
1401	N	-	-	-	-	-	-	2020	2330	2420	2550	2610	2800	-	-	-	
	kgf	-	-	-	-	-	-	206	238	247	260	266	285	-	-	-	
1500	N	-	-	-	-	-	-	-	-	-	-	-	3890	3890	3890	3890	
	kgf	-	-	-	-	-	-	-	-	-	-	-	397	397	397	397	
1501	N	-	-	-	-	-	-	2760	3140	3520	3890	3890	3890	-	-	-	
	kgf	-	-	-	-	-	-	281	320	359	397	397	397	-	-	-	

Note 1. The allowable thrust loads in the table are only applicable when a thrust load works in an output shaft drawing direction. When it works in an output shaft pushing direction, contact us on every occasion.

2. The allowable thrust loads in the table are when a radial load is not applied to the output shaft.

11.2 Moment of Inertia and GD²

Table 11

Motor type		0.1kW		0.2kW		0.4kW		0.75kW		1.5kW		2.2kW	
		Moment of inertia	GD ²	Moment of inertia	GD ²	Moment of inertia	GD ²	Moment of inertia	GD ²	Moment of inertia	GD ²	Moment of inertia	GD ²
		kg·m ²	kgf·m ²	kg·m ²	kgf·m ²	kg·m ²	kgf·m ²	kg·m ²	kgf·m ²	kg·m ²	kgf·m ²	kg·m ²	kgf·m ²
3 phase	W/o brake	0.00033	0.0013	0.00050	0.0020	0.00065	0.0026	0.00120	0.0048	0.00213	0.0085	0.00333	0.0133
	W/ brake	0.00035	0.0014	0.00055	0.0022	0.00068	0.0027	0.00130	0.0052	0.00235	0.0094	0.00373	0.0149

Note 1. The values in the table include the moment of inertia and GD² of the gear unit and motor unit.

2. The values in the table are subject to change without prior notice.

11.0 Technical Information: Gear Unit

11.3 Output Shaft End Dimensions

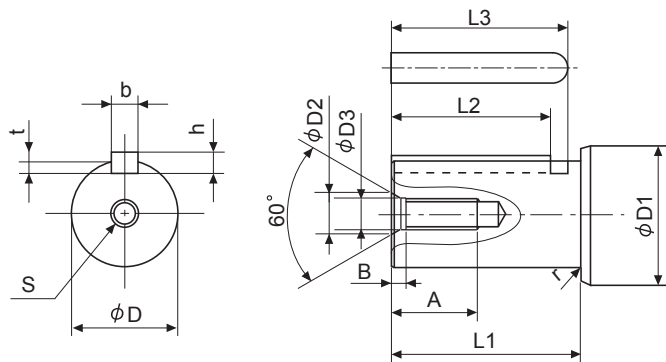

Fig. 10

Table 12

Frame no.	Tap dimension s	Tapping depth A	Center hole dimensions		
			φ D2	φ D3	B
1180	M6	12	9	6.2	3.4
1220 1221	M6	12	9	6.2	3.4
1280 1281	M8	16	11	8.2	3.6
1320 1321	M10	18	13	-	3.7
1400 1401	M10	18	13	-	3.7
1500 1501	M12	24	15	-	4

Table 13

Frame no.	φ D	Tolerance (h6)	φ D1	L1	r	t	Tolerance	b (key)	Tolerance (h9)	h (key)	Tolerance	L2 (key)	L3
1220 1221	22	0 -0.013	25	40	0.4	3.5	+0.1 0	6	0 -0.030	6	0 -0.030	32	35
1280 1281	28	0 -0.013	30	45	0.4	4	+0.2 0	8	0 -0.036	7	0 -0.090	36	40
1320 1321	32	0 -0.016	35	55	0.4	5	+0.2 0	10	0 -0.036	8	0 -0.090	45	50
1400 1401	40	0 -0.016	45	65	0.4	5	+0.2 0	12	0 -0.043	8	0 -0.090	54	60
1500 1501	50	0 -0.016	55	75	0.4	5.5	+0.2 0	14	0 -0.043	9	0 -0.090	63	70

The keyway dimensions comply with the JIS B 1301-1996 Parallel Keyways (Ordinary).
The information in this table is subject to change without prior notice.

11.4 Standard rust-proof specifications

Prior to shipment, our finished products are provided with rust-proof treatment based on the following standards.

(1) External rust-proof treatment

Rust-proof oil is applied prior to shipment. After shipment, check a rust-proof condition semi-annually and apply the oil again if necessary.

(2) Internal rust-proof treatment

Rust-proof period	1 year
Storage condition	To be stored inside a general factory building or warehouse free of humidity, dust, drastic temperature change, and corrosive gases.

12.0 Technical Information: Motor

12.1 Motor Type Designation

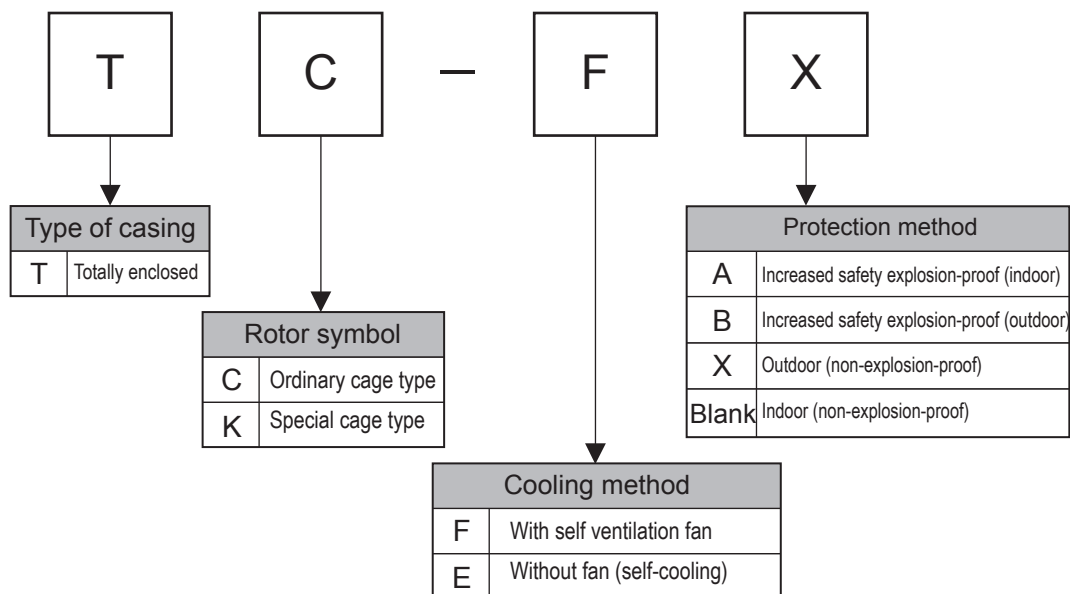

12.2 Dimensions of terminal box

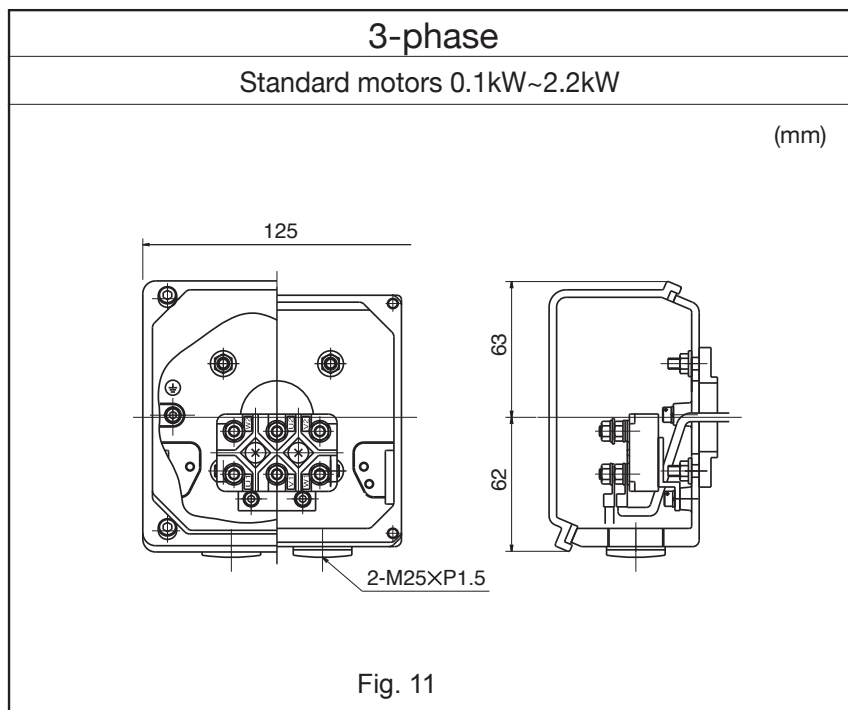

12.0 Technical Information: Motor

12.3 Motor Characteristics: CE-Marked Motors

3 Phase, Non-explosion Proof for Asia Pacific and Europe

Motor frame size	Pole	4 poles														
	Power	220V-50Hz					230V-50Hz					220V-60Hz				
	Output power (kW)	Full load current (A)	Largest torque (%)	Starting torque (%)	Starting current (A)	Speed (r/min)	Full load current (A)	Largest torque (%)	Starting torque (%)	Starting current (A)	Speed (r/min)	Full load current (A)	Largest torque (%)	Starting torque (%)	Starting current (A)	Speed (r/min)
V-63S	0.1	0.60	235	230	2.3	1420	0.62	261	261	2.3	1430	0.53	220	202	2.1	1700
V-63M	0.2	1.0	210	206	3.8	1410	1.0	231	236	4.0	1420	0.95	186	191	3.5	1690
V-71M	0.4	2.0	200	201	7.3	1410	2.1	221	229	7.8	1420	1.8	188	185	6.6	1680
V-80M	0.75	3.3	211	193	13.1	1420	3.3	219	215	13.8	1430	3.1	189	180	12.3	1720
V-90L	1.5	6.1	204	192	27.9	1420	6.0	228	224	28.9	1430	5.7	196	175	25.5	1700
V-100L	2.2	8.7	203	213	42.1	1420	8.3	231	255	45.0	1430	8.1	207	185	38.0	1690

Motor frame size	Pole	4 poles														
	Power	380V-50Hz					400V-50Hz					415V-50Hz				
	Output power (kW)	Full load current (A)	Largest torque (%)	Starting torque (%)	Starting current (A)	Speed (r/min)	Full load current (A)	Largest torque (%)	Starting torque (%)	Starting current (A)	Speed (r/min)	Full load current (A)	Largest torque (%)	Starting torque (%)	Starting current (A)	Speed (r/min)
V-63S	0.1	0.34	235	230	1.3	1420	0.36	261	261	1.3	1430	0.37	281	286	1.4	1430
V-63M	0.2	0.61	210	206	2.2	1410	0.62	233	236	2.3	1420	0.63	251	260	2.4	1420
	0.25	0.95	332	334	4.2	1460	1.0	365	379	4.5	1460	1.1	389	413	4.7	1460
V-71M	0.4	1.2	200	201	4.2	1410	1.2	221	229	4.5	1420	1.3	236	250	4.7	1420
	0.55	1.4	182	206	5.3	1410	1.4	200	225	5.5	1420	1.4	218	248	5.8	1420
V-80M	0.75	1.9	211	193	7.6	1420	1.9	219	215	8.0	1430	2.0	237	232	8.4	1440
V-90L	1.5	3.5	204	192	16.1	1420	3.5	228	224	17.1	1430	3.6	242	236	17.8	1430
V-100L	2.2	5.0	203	213	24.3	1420	4.8	231	255	26.0	1430	5.0	240	263	26.8	1430

*The values shown in the above tables are subject to change without notice. Contact us for confirming values.

Motor frame size	Pole	4 poles					
	Power	440V-60Hz					
	Output power (kW)	Full load current (A)	Largest torque (%)	Starting torque (%)	Starting current (A)	Speed (r/min)	
V-63S	0.1	0.32	300	289	1.4	1730	
V-63M	0.2	0.54	268	266	2.4	1720	
V-71M	0.4	1.0	256	262	4.6	1730	
V-80M	0.75	1.7	247	242	8.4	1740	
V-90L	1.5	3.0	250	243	17.5	1740	
V-100L	2.2	4.2	248	260	26.2	1720	

12.0 Technical Information: Motor

12.4 Motor Characteristics JIS Spec Motors

1) 200 V class (3Ø Non Explosion proof)

No. of poles		4 P														
Power supply		200V-50Hz					200V-60Hz					220V-60Hz				
Output [kW]	Motor Frame No	Rated current [A]	Max. torque [%]	Starting torque [%]	Starting current [A]	Rpm [r/min]	Rated current [A]	Max. torque [%]	Starting torque [%]	Starting current [A]	Rpm [r/min]	Rated current [A]	Max. torque [%]	Starting torque [%]	Starting current [A]	Rpm [r/min]
0.1	V-63S	0.69	265	281	2.7	1420	0.6	236	245	2.5	1700	0.62	285	297	2.8	1720
0.2	V-63M	1.24	232	233	4.6	1410	1.09	210	207	4.2	1700	1.09	254	250	4.8	1720
0.4	V-71M	2.35	237	237	9.1	1410	2.05	210	210	8.3	1700	2.02	257	257	9.4	1730
0.75	V-80M	3.88	234	215	16.0	1420	3.43	211	190	15.1	1720	3.35	253	242	16.8	1740
1.5	V-90L	6.97	233	224	34.1	1430	6.29	205	192	31.2	1710	6.00	250	243	34.9	1730
2.2	V-100L	9.74	268	255	52	1430	8.90	229	204	46.6	1700	8.38	282	260	52	1720

2) 400 V class (3Ø Non Explosion proof)

No. of poles		4 P														
Power supply		400V-50Hz					400V-60Hz					440V-60Hz				
Output [kW]	Motor Frame No	Rated current [A]	Max. torque [%]	Starting torque [%]	Starting current [A]	Rpm [r/min]	Rated current [A]	Max. torque [%]	Starting torque [%]	Starting current [A]	Rpm [r/min]	Rated current [A]	Max. torque [%]	Starting torque [%]	Starting current [A]	Rpm [r/min]
0.1	V-63S	0.36	255	261	1.3	1420	0.31	219	224	1.2	1700	0.32	277	289	1.4	1720
0.2	V-63M	0.62	233	236	2.3	1410	0.55	202	202	2.1	1700	0.55	257	266	2.4	1720
0.4	V-71M	1.23	229	229	4.5	1420	1.04	197	201	4.1	1700	1.04	249	262	4.6	1740
0.75	V-80M	1.94	234	215	8.0	1420	1.72	211	190	7.6	1720	1.68	253	242	8.4	1740
1.5	V-90L	3.49	233	224	17.1	1430	3.15	205	192	15.6	1710	3.00	250	243	17.5	1730
2.2	V-100L	4.87	268	255	26.0	1430	4.45	229	204	23.3	1700	4.19	282	260	26.0	1720

*The values in the above table are subject to change without prior notice.

12.5 Motor Characteristics: Increased Safety (eG3) Motors

Increased safety motors conform to eG3 of Japanese Industrial Standards (JIS)

a. 200V class

Motor frame size	Pole	4 poles														
	Power	200V-50Hz					200V-60Hz					220V-60Hz				
		Output power (kW)	Full load current (A)	Largest torque (%)	Starting torque (%)	Starting current (A)	Speed (r/min)	Full load current (A)	Largest torque (%)	Starting torque (%)	Starting current (A)	Speed (r/min)	Full load current (A)	Largest torque (%)	Starting torque (%)	Starting current (A)
V-63S	0.1	0.69	274	281	2.7	1430	0.60	255	245	2.5	1710	0.62	311	297	2.8	1730
V-63M	0.2	1.2	238	233	4.6	1420	1.1	223	207	4.2	1700	1.1	273	250	4.8	1720
V-71M	0.4	2.3	221	237	9.1	1410	2.0	203	210	8.3	1700	2.0	249	257	9.4	1730
V-80M	0.75	3.9	219	215	16.0	1430	3.4	203	190	15.1	1730	3.3	247	242	16.8	1740
V-90L	1.5	7.0	228	224	34.1	1430	6.3	206	192	31.2	1720	6.0	250	243	34.9	1740
V-100L	2.2	9.6	231	255	52	1430	8.8	204	204	46.9	1710	8.3	248	260	52	1720

b. 400V class

Motor frame size	Pole	4 poles														
	Power	400V-50Hz					400V-60Hz					440V-60Hz				
		Output power (kW)	Full load current (A)	Largest torque (%)	Starting torque (%)	Starting current (A)	Speed (r/min)	Full load current (A)	Largest torque (%)	Starting torque (%)	Starting current (A)	Speed (r/min)	Full load current (A)	Largest torque (%)	Starting torque (%)	Starting current (A)
V-63S	0.1	0.36	261	261	1.3	1430	0.31	246	224	1.2	1710	0.32	300	289	1.4	1730
V-63M	0.2	0.62	233	236	2.3	1420	0.54	219	202	2.1	1700	0.54	268	266	2.4	1720
V-71M	0.4	1.2	221	229	4.5	1420	1.0	209	201	4.1	1700	1.0	256	262	4.6	1730
V-80M	0.75	1.9	219	215	8.0	1430	1.7	203	190	7.6	1730	1.7	247	242	8.4	1740
V-90L	1.5	3.5	228	224	17.1	1430	3.1	206	192	15.6	1720	3.0	250	243	17.5	1740
V-100L	2.2	4.8	231	255	26.0	1430	4.4	204	204	23.5	1710	4.2	248	260	26.2	1720

12.0 Technical Information: Motor

12.6 Built-in Brake Specification

Brake specification of 3-phase motors (standard)

Brake type	Output power (4 poles)	Standard torque (Nm)	Moment of inertia ($1 \times 10^{-4} \text{kg} \cdot \text{m}^2$)	Total braking energy ($\times 10^7 \text{J}$)	Motion delay (Sec)		Brake current (A)			Brake current (A) (Non-standard Brake Voltage)		
					Standard control circuit	Quick braking circuit	220V50Hz	230V50Hz	220V60Hz	400V50Hz	400V60Hz	440V60Hz
FB-01A	0.1kW	1.0	3.6	12	0.15~0.2	0.015~0.02	0.08	0.08	0.08	0.04	0.04	0.04
FB-02A1	0.2kW	2.0	5.6	12			0.1	0.1	0.1	0.05	0.05	0.06
FB-05A1	0.25kW 0.4kW	4.0	6.9	12	0.1~0.15	0.01~0.015	0.1	0.1	0.1	0.05	0.05	0.06
FB-1D	0.55kW 0.75kW	7.5	13	33	0.2~0.3	0.01~0.02	0.1	0.1	0.1	0.1	0.1	0.1
FB-2D	1.1kW 1.5kW	15	24	38			0.3	0.3	0.3	0.1	0.1	0.2
FB-3D	2.2kW	22	38	45			0.3	0.3	0.3	0.1	0.1	0.2

- Continuous time rating for Motor as well as brake.
- Non-asbestos lining is used for brake.
- Mechanical life time of brake is as long as 2 million times under normal usage conditions.
- Rectifiers of FB brake is built in the brake for 40-90W and in the terminal box for 0.1kW and above. Rectifiers of SB brake is supplied separately.
- To improve the elevating device and stopping accuracy, use the quick braking circuit.
- Low-noise type FB brake is available optionally. (FB-01A2-FB-8B)
- FB brake is direct current and spring braking type (non-electrical braking).
- The above standard torque indicates the value of dynamic friction torque.
- Standard brake voltage is 200V class. 400V class brake is non-standard.

Output power of a rectifier in 3-phase brake

Input voltage	Output voltage
AC200V	DC90V
AC220V	DC99V
AC400V	DC180V
AC440V	DC198V

Why quick braking circuit shortens braking time.

See Fig 12 and Fig 13 for differences between standard braking circuit and quick braking circuit. See Fig 14 and Fig 15 for current curves of standard braking circuit and quick braking circuit.

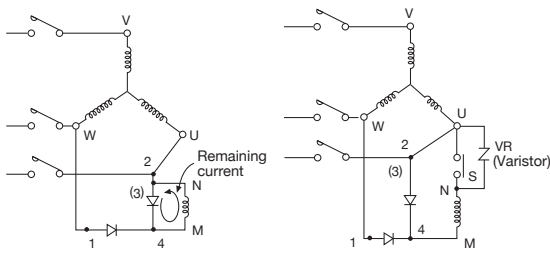

Fig. 12 standard circuit

Fig. 13 quick braking circuit

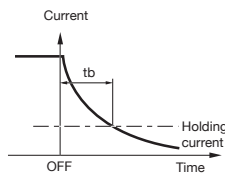

Fig. 14 current curve of standard braking circuit

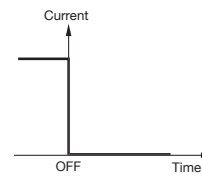
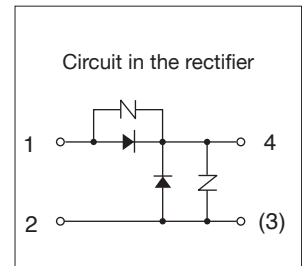

Fig. 15 current curve of quick braking circuit



In the standard circuit as Fig 12, some current remains after the power is turned off due to the saved energy in the inductance L of brake coil. The current curve is shown in the Fig. 14. When it is connected to quick braking circuit as the Fig 13 and S is released at the same time, no current remains as there is no closed

circuit with the brake coil. (See the Fig. 15.) Therefore, it shortens the braking time by t_b in the Fig 14. Quick braking circuit is to release all current by ON/OFF of brake coil at the same time with power ON/OFF. (VR varistor must be used to protect the rectifier and connection S.)

12.0 Technical Information: Motor

12.7 Wiring Diagram: Standard 3-Phase Motors

Wiring diagram for standard motors

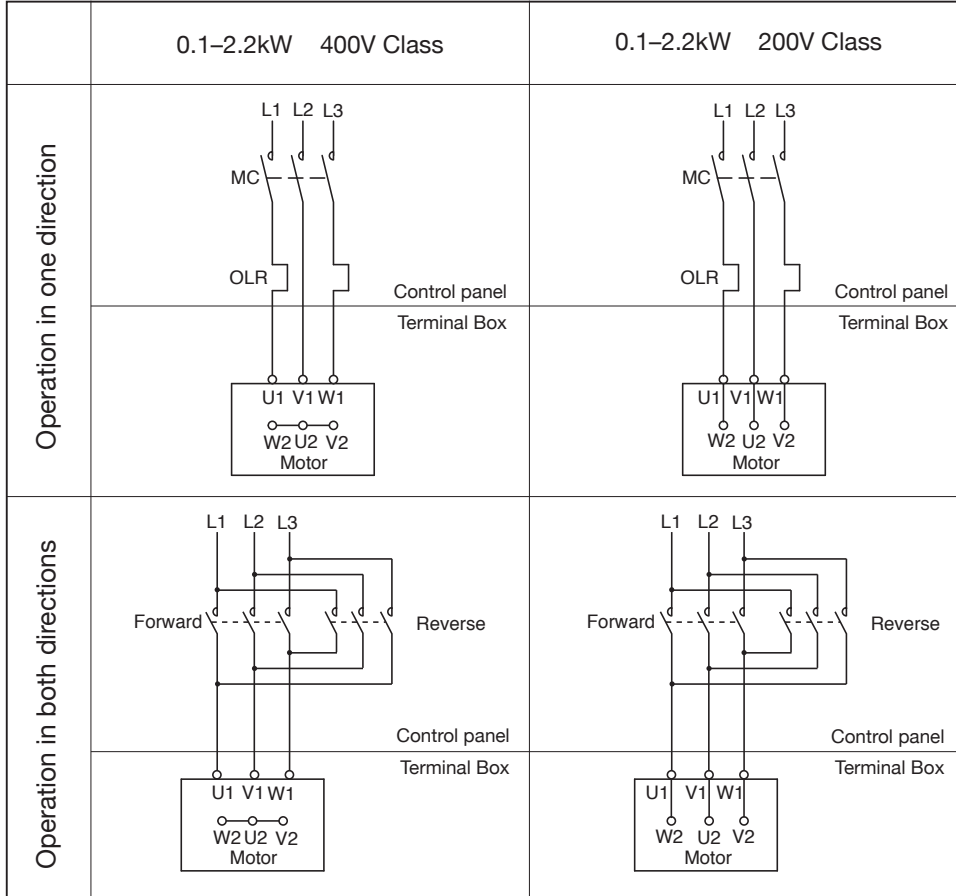

Note:

MC: Electromagnetic contactor
OLR: Overload relay or thermal relay

These should be furnished by the customer.

Example of wiring

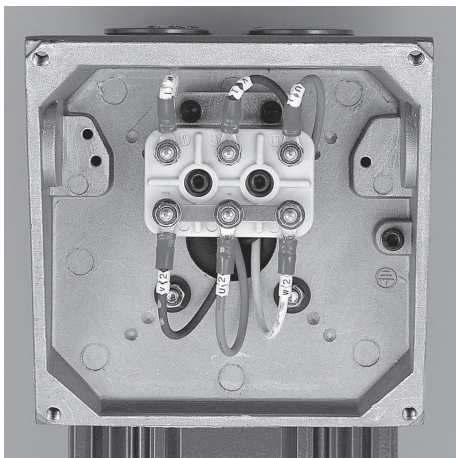

0.1–2.2kW 400V Class

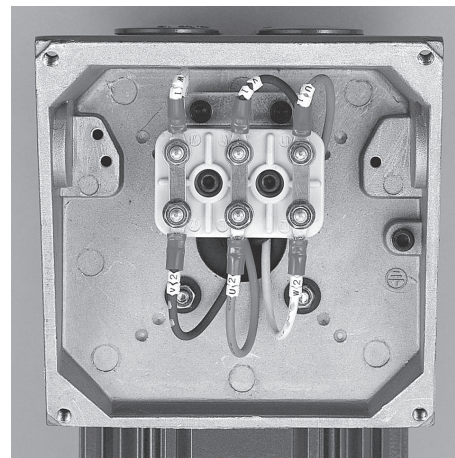

0.1–2.2kW 200V Class

Fig. 16

12.0 Technical Information: Motor

12.8 Wiring Diagram: 3-Phase Motor With Brake

3-Phase Motor with Brake : 0.1kW×4P~2.2kW×4P (FB-01A~FB-3B)

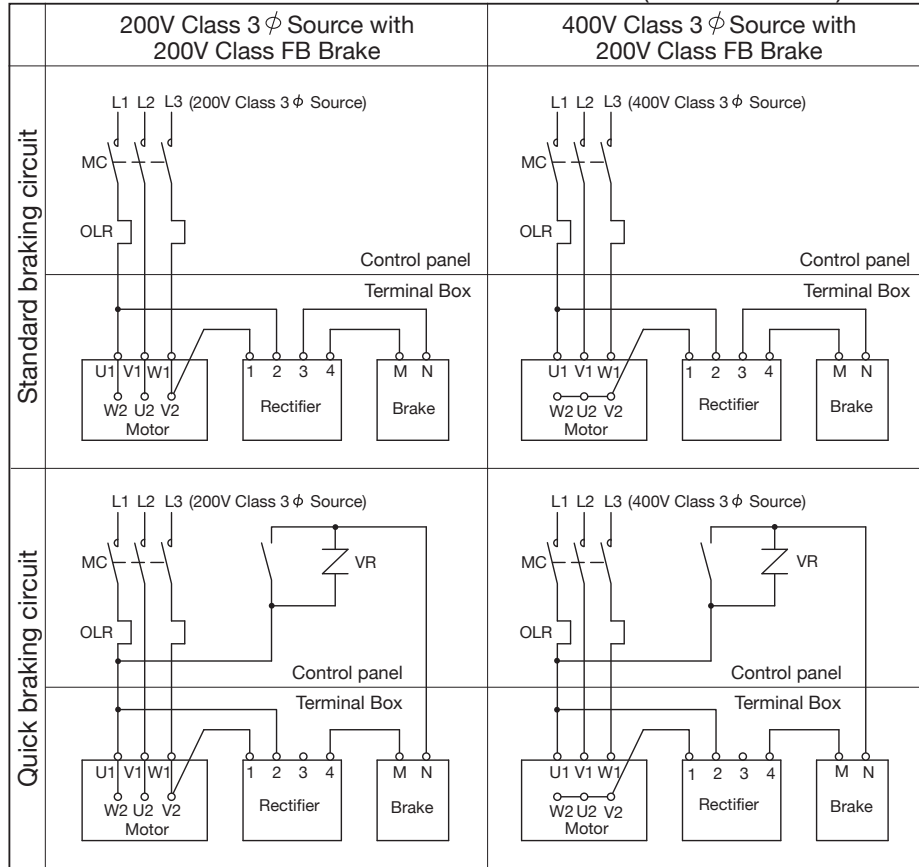

• For 400V Class brake wiring diagram, consult factory.

• Electromagnetic contactor and OLR: Overload relay are not supplied by Sumitomo.

VR: varistor is optionally available at Sumitomo.

Brake input power	AC200V~230V	AC380V~460V
Rated voltage of varistor	AC260~AC300V	AC510V
Varistor voltage	430V~470V	820V
Rated capacity of varistor	FB-01A1,02A1,05A1	0.2Watt and above
	FB-1B	0.4Watt and above
	FB-2B,3B	0.6Watt and above

• To improve the elevating device and stopping accuracy, use the quick braking circuit.

• Connection capacity of quick braking circuit is recommended to have more than five times of braking capacity (direct current coil load) of the brake current shown on the table in page 37.

3-Phase Motor with Brake : 0.1kW×4P~2.2kW×4P (FB-01A~FB-3B)
(Forward & Reverse Mode Connection)

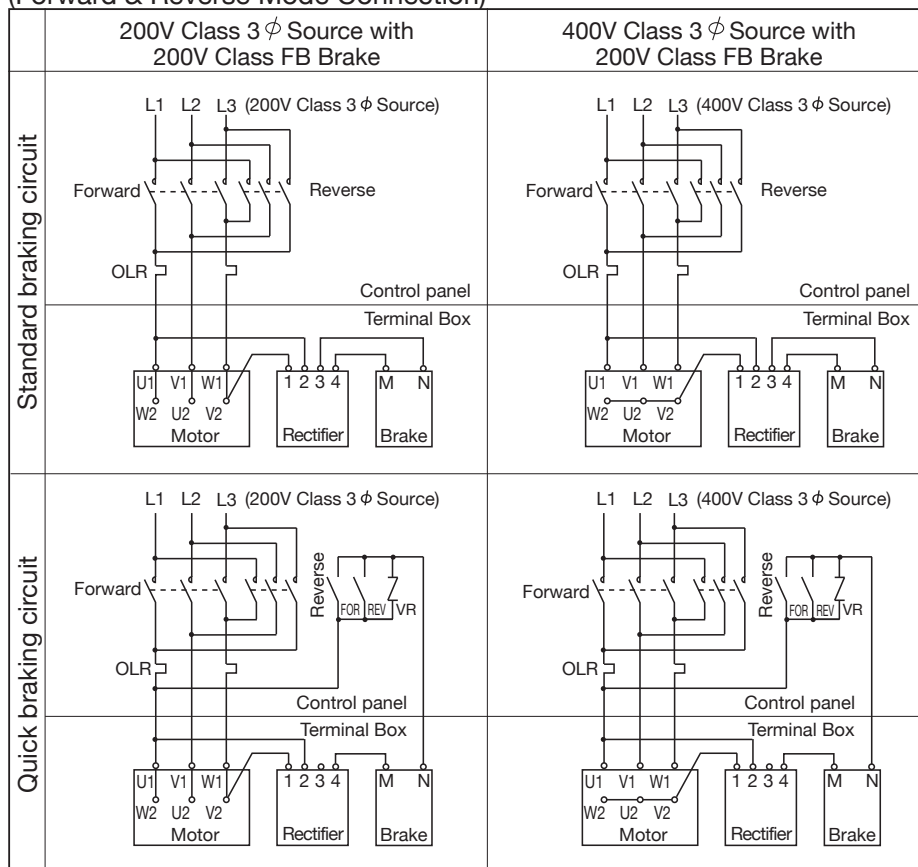

Note 1: Refer to instruction manuals and guide manual of inverter for interlocking with inverter required in MC ON/OFF.

Note 2: Connection capacity for quick braking circuit is recommended to have more than five times of braking capacity (direct current coil load) of the brake current shown on the table in page 37.

• VR: varistor is optionally available at Sumitomo.

Brake input power	AC200V~230V
Rated voltage of varistor	AC260~AC300V
Varistor voltage	430V~470V
Rated capacity of varistor	FB-01A1,02A1,05A1
	FB-1D
	FB-2D, 3D, 5B, 8B

Brake input power	AC380V~460V
Rated voltage of varistor	AC510V
Varistor voltage	820V
Rated capacity of varistor	FB-01A1,02A1,05A1
	FB-1D
	FB-2D, 3D, 5B, 8B

12.0 Technical Information: Motor

12.9 Motor Protection

No.1 Symbol form of protection of humans and solid foreign substances } Classified according to combination.
 No.2 Symbol form of protection against water permeation

Protection Method of Motors

No.1 Symbol No.1 Form	No.2 Symbol No.2 Form	0 Non-protected type	2 Drip-proof type	3 Spray-proof type	4 Splash-proof type	5 Water-jet-proof type	6 Sea-wave-proof type	7 Immersion-proof type	8 Submersible type
0 (Non-protected type)		IP00			X	X	X	X	
1 (Semi-protected type)		IP10	IP12S			X	X	X	
2 (Protected type)		IP20	IP22S	IP23S	IP24	X	X	X	
4 (Totally enclosed type)		X			IP44	IP45			
5 (Dust-proof type)		X			IP54	IP55	IP56		
6 (Complete dust-proof type)		X				IP65			

Note 1: X mark denotes difficulty in forming the combination.
 Note 2: Outlined columns denote the manufacturing range of Sumitomo.
 Note 3: Contact us for motors of JP45 and JP55.

Class of No.1 Symbol

Type	Symbol	Description
Non-protected	0	Constructed without special protection against human contact and penetration of solid foreign substances.
Semi-protected	1	Constructed to prevent inadvertent contact with rotating and conductive parts inside the machine, by hand or other critical parts of human body. Constructed to prevent penetration of solid foreign substances over 50 mm in diameter.
Protected	2	Constructed to prevent contact with rotating and conductive parts inside the machine, by hand or other critical parts of the human body. Constructed to prevent penetration by solid substances over 12mm in diameter.
Totally enclosed	4	Constructed to prevent contact with the rotating and conductive parts inside the machine, by tools, electric wires, etc., with minimum width and thickness over 1mm. Constructed to prevent penetration of solid foreign substances over 1mm diameter. However, water drainage outlet and exhaust outlet may be of Symbol 2 construction.
Dust-proof type	5	Constructed to prevent contact with rotating and conductive parts inside the machine by any form of object. Constructed for maximum protection against dust particles penetration, but will not interfere with normal operation, despite of such penetration.
Complete dust-proof type	6	Constructed for complete protection against dust particles penetration.

Class of No.2 Symbol

Type	Symbol	Description
Non-protected	0	Constructed without special protection against water permeation.
Drip-proof	2	Constructed to prevent harmful effect from dripping water falling from within 15° direction from vertical.
Spray-proof	3	Constructed to prevent harmful effect from dripping water falling from within 60° direction from vertical.
Splash-proof	4	Constructed to prevent harmful effect from dripping water falling from any direction.
Water-jet-proof	5	Constructed to prevent harmful effect from spray from any direction.
Sea-wave-proof	6	Constructed to prevent harmful effect from strong spray from any direction.
Immersion-proof	7	Constructed for submersion into water of prescribed depth and time, but not having any harmful effect in spite of water permeation.
Submersible	8	Constructed to assure normal operations under water.

Example:

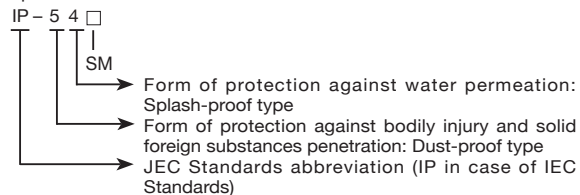

S..... Test of form of protection against water permeation, conducted when motor is stopped.
 M..... Test of form of protection against water permeation, conducted while motor is operating.
 When no S or M stipulated... Test conducted when motor stopped and when operating

Cooling

Enclosure Construction	IEC Standards
Totally enclosed, non-ventilated (TENV)	IC410
Totally enclosed, fan-cooled (TEFC)	IC411

13.0 Construction Drawing

13.1 Gear Motor Construction

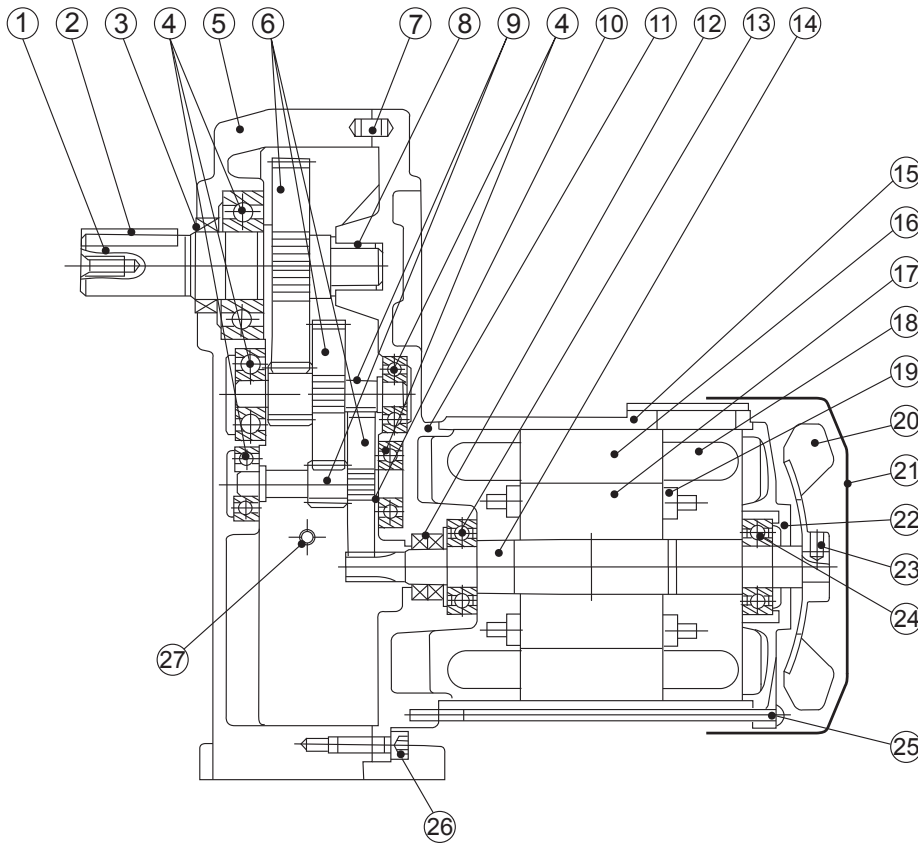

Part No.	Part Name
1	Output Shaft
2	Key
3	Oil Seal
4	Bearing
5	Casing
6	Gear
7	Parallel Pin
8	Plain Bearing
9	Pinion
10	Distance
11	Motor Flange Bracket
12	Oil Seal
13	Bearing
14	Motor Shaft
15	Motor Frame
16	Stator Core
17	Rotor Core
18	Stator Windings
19	Rotor Conductor
20	Fan
21	Fan Cover
22	Bracket
23	Non-Drive End Bracket
24	Set Bolt
25	Bearing
26	Bolt
27	Bolt
28	Plug Note

Fig. 17 Gear Motor Construction with Legs

Note: The frames No. 1180, 1220 and 1221 do not include the plug (No. 27).

13.2 Brake Construction Drawing

Fig 18 FB-01A1, 02A1, 05A1 (0.1kW~0.4kW x 4P)
(FB-01A1 without fan)

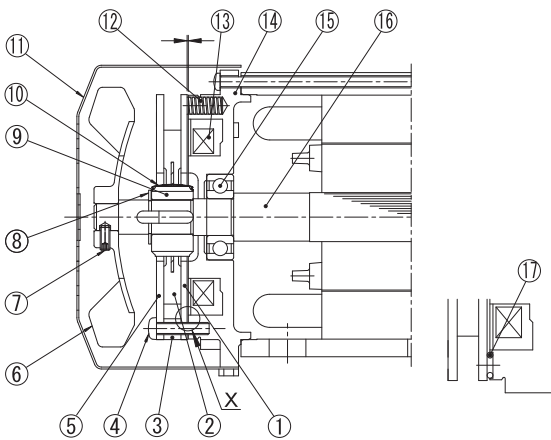

Part no.	Part name	Part no.	Part name
1	Movable core	10	Leaf spring
2	Brake lining	11	Cover
3	Spacer	12	Torque spring
4	Assembling bolt	13	Electromagnetic coil
5	Fixed plate	14	Stationary core
6	Fan	15	Ball bearing
7	Fan set bolt	16	Motor shaft
8	Shaft retaining C ring	17	Buffer
9	Boss		

Fig 19 FB-1D, 2D, 3D (0.75kW~2.2kW x 4P)

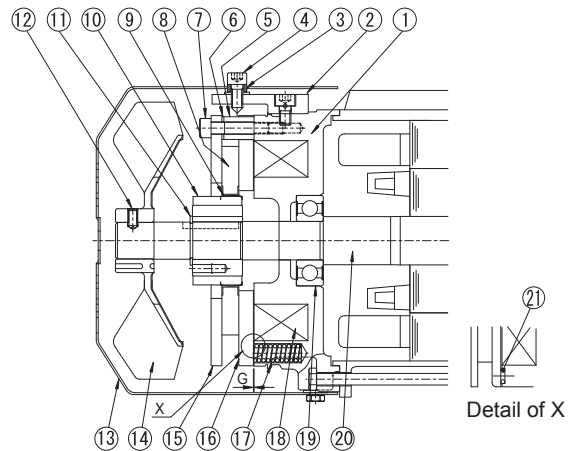

Part no.	Part name	Part no.	Part name
1	Stationary core	12	Fan set bolt
2	Release fitting	13	Cover
3	Manual release protection spacer	14	Fan
4	Brake release bolt	15	Fixed plate
5	Spacer	16	Movable core
6	Gap adjusting shim	17	Spring
7	Assembling bolt	18	Electromagnetic coil
8	Brake lining	19	Ball bearing
9	Leaf spring	20	Motor shaft
10	Boss	21	Buffer
11	Shaft retaining C ring		

14.0 International Standards And Compliance Of Sumitomo Products

CCC Standards (China Compulsory Certification)

China had implemented the China Compulsory Certification (CCC) system since May 1, 2002 as becoming the full member of World Trade Organization (WTO). They have moved on to compulsory licensing on August 1, 2003. Motor capacity 1.1kW and below are subject to this certification, and requires CCC Mark for sales in China. Below table is our motor with CCC.

Motor	Single Phase Motor		Three Phase Motor		AF Motor	AF Motor (Foot Mount)
Capacity	15~90W	0.1~0.75kW	40~90W	0.1~1.1kW	0.1~0.75kW	0.4~0.75kW
Voltage	220V		220 or 380V			
Frequency	50Hz		50Hz			
Thermal class	Class E	Class B	Class E	Class F		
Usage	Indoor (IP44), Outdoor (IP55)		Indoor (IP44), Outdoor (IP55)			

AF motor: 3 Phase Motor for inverter

Difference with standard items

- CCC Mark as in the right is applied on the nameplate.
- Aluminum terminal box is the standard for three phase motor (except indoor specification for 40~90W).
- Terminal block type (6 terminals, European system) is the standard for three phase motor (for 0.1kW or more).
- Rotational direction is the opposite from Japanese domestic specification (in CCW direction looking from the anti-load side).
- CCC correspondence motor coil is used.



China Compulsory Certificate

Remarks

- CCC Mark is necessary when exporting small size motor (or gear motor) units of 1.1kW or below to China.
- Subject service products and spare parts without certification may be permitted for import to China by applying for exemption. Consult us for any clarification.

GOST-R Standard (Russian Gosstandard)

GOST-R Standard is a national certification system determined by State Committee of Russian Federation for Standardization and Metrology.

Any product distributed in the Russian Federation requires certification. Especially products subject to compulsory certification are not allowed to export to Russian Federation without this certification.

Sumitomo offers motors conforming to GOST-R specification for export to Russia, because motors are subject to compulsory certification.

Our Certified Motor Specification (Range other than the below is the same as CE Marking of Europe.)

Motor	General motor				Inverter motor (AF motor)			
	Without brake	With brake	Without brake	With brake	Without brake	With brake	Without brake	With brake
Capacity x 4P	0.1~3.7kW	5.5kW	0.1~3.7kW	5.5kW	0.1~2.2kW	3.7kW	0.1~2.2kW	3.7kW
Motor voltage	220/380V	380V	220/380V	380V	220/380V	380V	220/380V	380V
Brake voltage	-	-	220V	380V	-	-	220V	380V
Frequency	50Hz				60Hz			
Thermal class	F				F			
Rating	S1 (continuous)				S1 (continuous)			
Construction	Indoor (IP44), Outdoor (IP55)				Indoor (IP44), Outdoor (IP55)			
Starting	Dual voltage inline	$\lambda - \Delta$	Dual voltage inline	$\lambda - \Delta$	-			

AF motor: 3-Phase Motor for inverter

Difference Compared to Standard Japanese Product

- Nameplate is marked with GOST-R Mark (as shown in the right).
- Standard terminal box is made of Aluminum
- The motor has terminal block (European type with 6 terminals).
- Rotation direction is counterclockwise viewed from fan cover side (opposite from Japanese specification).
- Motor coil is certified for GOST-R.



GOST-R Mark

Cautions

- Uncertified products cannot pass through customs when exported to Russia. (No specific certification is necessary when the unit is exported to Russia as a part of the machine.)
- A verified copy of the certification is necessary when exporting the individual unit for each case (each ship). Let us know when ordering the units which are not included in an apparatus or not built into the exported apparatus.

14.0 International Standards And Compliance Of Sumitomo Products

CE MARKING

The CE mark is to be affixed to products that conform to EC directives, in order to certify the quality and safety of products and ensure free distribution of products across borders within the region of the EU (European Union).

EC directives applicable to machine products and implementation period

The following three directives apply to ordinary machine products.

EC directives	Details	Objects	Details of directive
Machinery directive		Aggregates of parts, which are movable (Industrial machines, primarily)	Essential matters related to safety of machines are stipulated. Machines that are electrically dangerous shall fulfill the requirements for low voltage.
Low Voltage Directive		Products driven by power of 50-1,000 VAC or 75-15,000 VDC	Products not conforming to standards cannot be put on the market.
EMC Directives Electromagnetic Compatibility Directive		All types of products that may cause jamming (electromagnetic radiation) or have their functions impeded by nearby radio waves	EMI : Not to cause external electromagnetic interference EMS : To withstand external electromagnetic interference

Standard Specifications of CE Marking Motors

Input power	: 15W~90W 200V 50Hz Direct start-up 0.1kW~4kW 230/400V 50Hz Dual voltage direct starting 5.5kW or more 400V 50Hz λ - Δ Start
Insulation	: 15W~0.4kW Class E 0.75kW or more Class B
Rated time	: Continuous
Characteristics	: IEC34-1
Protection	: P54 (without brake), IP44 (with brake) 15W~90W : Aluminum (M20 bolts(P1.5)X1pcs)
Terminal box	: (Material) 5.5kW or less : Aluminum (PG16 boltsX2pcs or M25 bolts (P1.5)X2pcs) 7.5kW or more : cast iron (PG21 boltsX2pcs or M32 bolts (P1.5)X2pcs) (specification) Terminal plate (six terminals European style) with grounding terminal Conduit tube in European size (* PG thread or M thread) *different from Japanese standard of conduit tube PF thread. Models of 15W~90W contain M thread and cable ground (applicable lead diameter P6.0~12)
Shaft rotating direction	: Rotating direction is reverse to Japanese standard direction.
Insulation	: Distances between insulated surfaces and spaces in accordance with IEC standards.
External dimensions	: Same as standard except for the terminal box Length might vary in some cases for models 90W or less.
TÜV test report	: Acquired for a representative model 0.75kWX4p, 230V/400V (Oct 1996) CE marking motors are manufactured in accordance with the model.
Declaration of Conformity	: Declaration of Conformity is available when necessary for CE marking

Manufacturing range of CE Marking motors

3-phase induction motor

Input power symbol	230/400V dual voltage													
	0015	0025	004	006	009	01	012	018	02	03	04	05	08	1
kWx4P	(0.015)	(0.025)	(0.04)	(0.06)	(0.09)	(0.1)	0.12	0.18	(0.2)	0.25	0.37	(0.4)	0.55	0.75
Frame	F50S	F50M	F50L or F56S	F50L or F56M	F56L	V63S		V63M		V71M		V80S	V80M	

Input power symbol	230/400V dual voltage						400V
	1H	2	3	4	5	6	8
kWx4P	1.1	1.5	2.2	3	(3.7)	4	5.5
Frame	V90S	V90L	V100L	V112S	V112M		V132S

- Motors of kW without brackets () in the above table are standard in Europe while motors of kW with brackets () are used only in Japan and other countries.
- European standard kW motors are recommended. Motors of kW with brackets () are also available.
- 3-phase 200V/50Hz, 200V/60Hz, 220V/60Hz 3-phase 400V/50Hz, 400V/60Hz, 440V/60Hz 3-phase 380V/50Hz, 3P 415V/50Hz
- Contact us when motors of kW and voltage not shown in the above table are required.
- Consult us when M bolt (Metric bolt) is needed for conduit tube.

Measures to take for EC directives and CE marking related to gear motors

Among EC directives, the machinery directive (issued in January 1995) concerning induction motors and low voltage directive (issued in January 1997) are applicable.
The EMC directive (issued in January 1996) does not apply to induction motors.

CE marking logo shown on nameplates



14.0 International Standards And Compliance Of Sumitomo Products

UL Standards (Underwriters Laboratories)

UL Standards are established for safety by a commercial testing institute in the US to prevent harmful effect to human life, fire and disaster based on a series of scientific study, research and experiment. It is not regulated to comply with the standards by Federal Government, but it is regulated by some states or cities. Approved products by UL standards are highly appreciated in the US to represent your reliability.

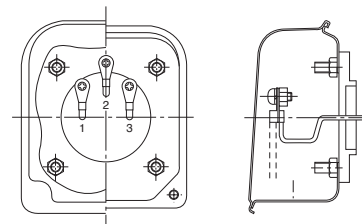

3-Phase indoor terminal box

- *1. Single-phase motor or motor w/brake is manufactured in the range of 1/50 through 1/9 HP.
- *2. Outdoor type is available. Please consult us.
- *3. F-class insulation type is available. Please consult us.
- *4. For other voltages or frequencies, please consult us.

Differences from Sumitomo standard models

- Terminal symbol: 1,2,3
- Name plate with UL mark and measurement in HP
- Opposite rotating direction
- Copper terminal box
- UL standard motor coil and brake coil



SM-CYCLO® 3 PHASE INDUCTION MOTOR		UL
HP	P	TYPE
VOLTS		FRAME
Hz		INS CLASS
AMP		TIME RATING
RPM		SERVICE FACTOR
CODE		MAX AMB °C
SER. NO.		

SUMITOMO MACHINERY CORP. OF AMERICA
CHESAPEAKE, VIRGINIA

UL nameplate

Remarks

- Manufacturing and repair work may be conducted only at authorized factories.
- Motor for inverter is excluded from UL approval. Sumitomo supplies UL compliant AF motor. (UL mark is not fixed on a nameplate of UL compliant products.)

CSA Standards (Canadian Standard Association)

National standards established by a semi-governmental organization in Canada. Most states in Canada require electronic products to be approved by CSA. CSA is considered equivalent in some states in the US.

Motor	3-phase induction motor	3-phase induction motor with brake	High efficiency 3-phase induction motor *1	High efficiency 3-phase induction motor with brake *1
Power	1/8-1HPX4P	1/8-1HPX4P	1.5-5HPX4P	1.5-5HPX4P
Voltage	208V, 230V, 460V, 575V		230V, 460V, 575V	
Frequency	60Hz			
Insulation	Class B (and Class F)			
Ambient conditions	Indoor type *2			

- *1: Contact us for manufacture of a single-phase motor or a high-efficiency motor with brake. *2: Outdoor type not supplied
- *3: Some 1/50 through 1/9HPX4P are CUL approved products which are permitted for us in Canada.

Differences from Sumitomo standard models

- Terminal symbol: 1,2,3 (with Brake type, T₁, T₂, T₃)
- The frame size of a high-efficiency motor is special.
- Name plate with CSA mark and measurement in HP
- Opposite rotating direction
- Copper terminal box
- CSA standard motor coil

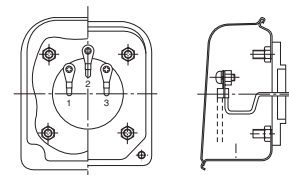

3-Phase indoor terminal box

Remarks

- If exporting to Canada, it should be CSA approved motor and if above 1HP, High efficiency motor is needed.
- Manufacturing and repair work may be conducted only at authorized factories.
- Motor for inverter is excluded from CSA approval. Sumitomo supplies CSA compliant AF motor. (CSA mark is not fixed on a nameplate of CSA compliant products.)
- NRCan established the energy efficiency act (EEACT) in 1992 and the energy efficiency regulations (EER) in 1995, and additional regulations were applied to gear motors imported on November 27, 1999 or later. Import of gear motors that do not meet the efficiency standards has been banned. This rule applies to the following motors : 1-200HP, IEC frame 90 and larger, 600V or less, constant speed.

TM		CSA
HP	P	TYPE
VOLTS		FRAME
Hz		M/B INS CLASS
M.AMP		TIME RATING
RPM		SERVICE FACTOR
B.AMP		MAX AMB °C
B.TORQUE	FT-LB	ENCLOSURE
MANUF. No.		TE

SUMITOMO SM CYCLO OF CANADA, LTD
TORONTO, MONTREAL, VANCOUVER

CSA nameplate

14.0 International Standards And Compliance Of Sumitomo Products

NEMA Standards (National Electrical Manufacturers Association)

Established by a manufacturers' association to provide standards of most electrical products for both manufacturers and consumers.

Differences from Sumitomo standard models

- Terminal symbol: 1,2,3
- Name plate marked with NEMA DESIGN and measurement in HP
- Opposite rotating direction
- Copper terminal box
- NEMA standard motor coil

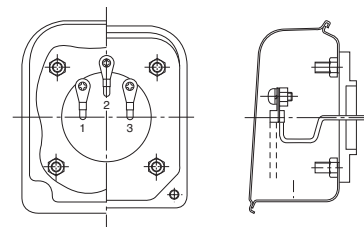

3-Phase indoor terminal box

Remarks

- No approval is required to state NEMA compliance.
- NEMA is also applicable for inverter motor, but limited to terminal symbols, measurement in HP, rotating direction and terminal box.

HP P TYPE /	
VOLTS	FRAME -
Hz	M/B INS. CLASS /
M. AMP	TIME RATING
RPM	SERVICE FACTOR
CODE	MAX. AMB. °C
B. AMP	B. TORQUE FT-LB
SERIAL NO.	NEMA DESIGN

Sumitomo Heavy Industries, Ltd.
J A P A N

NEMA nameplate

Other standards

Application of International Standards (Example)

● : Sumitomo standards

■ : Manufactured to special specification on customer's request

Country/Standards	Japan JIS JEM JEC	International-IEC	UK · BS	Germany · VDE DIN
Standard output	●	●	■ : 4kWmax. ● : 5.5kWmin.	■ : 4kWmax. ● : 5.5kWmin.
Applicable output frame size	●	—	■	■
Motor mounting dimension of corresponding frame size	●	●	●	●
Shaft end dimension	●	●	■	■
Dimension tolerance of shaft end key and key groove	●	●	■	■
Insulation class	●	●	●	—
Lead wire code	●	●	●	●
Standard direction of rotation	●	■	■	■
Description on nameplate	●	■	■	■
Characteristic testing method	●	●	■	■
Standard voltage	200V · 220V 400V · 440V	■	415V	220V 380V
Standard frequency	50Hz · 60Hz	50Hz · 60Hz	50Hz	50Hz

IEC—International Electrotechnical Commission.
BS—British Standards.

(Note): Dimensions of flanges and shafts are suitable for Sumitomo products only. For other dimensions, consult factory.

Major Japanese Standards

(1) General rotating electrical machines

JIS C 4004 (1992) : General rules for rotating electrical machines

JEC-200 (1993) : Rotating machinery in general

JEM 1188 (1969) : Rated output values of electric motors

(2) General 3-phase induction motors

JIS C 4210 (1983) : Low-voltage 3-phase squirrel cage induction motors for general purpose

JIS C 4212 (2000) : High efficiency low-voltage 3-phase squirrel cage induction motors.

JEC-37 (1979) : Induction machines

(3) Methods of testing and calculating characteristics

JEC-37 (1979) : Induction machines

JIS C 4207 (1995) : Calculating method of 3-phase induction motors characteristics

(4) Dimensions

JEM 1400 (1991) : Dimension of low-voltage 3-phase squirrel cage induction motors for general purpose

JEM 1401 (1991) : Dimensions of flange-mounted low-voltage 3-phase squirrel cage induction motors for general purposes

(5) Explosion-proof construction

JIS C 0903 (1983) : Electrical apparatus for explosive atmospheres in general industries

JIS C 0904 (1983) : Test methods on electrical apparatus for explosive gas atmospheres in general industries

JIS C 0905 (1983) : Supplementary requirements for construction of electrical apparatus for explosive atmosphere in general industries

Recommended practices for explosion-protected electrical installations in general industries (1979)

Rules for authorization of explosion-proof construction of electrical machine tools (1981)

(6) Others

JIS C 4003 (1977) : Classification of materials for insulation of electrical machinery and apparatus

JEC-147 (1960) : Classification of materials for insulation of electrical machinery and apparatus

JEM 1313 (1983) : Noise levels for low-voltage 3-phase squirrel-cage induction motors for general purpose

Remarks: JEC Japanese Electrotechnical Committee Standards

JIS Japanese Industrial Standard

JEM Japan Electrical Manufacturers' Association

15.0 Miscellaneous

15.1 Moment of inertia

(1) Moment of inertia of rotating motion

Rotating motion on the center of gravity		Rotating motion off the center of gravity	
	$J = \frac{1}{8} MD^2 \text{ [kg}\cdot\text{m}^2]$		$J = \frac{M}{4} \left(\frac{1}{2} D^2 + 4R^2 \right) \text{ [kg}\cdot\text{m}^2]$
	$J = \frac{1}{8} M (D^2 + d^2) \text{ [kg}\cdot\text{m}^2]$		$J = \frac{M}{4} \left(\frac{a^2 + b^2}{3} + 4R^2 \right) \text{ [kg}\cdot\text{m}^2]$
	$J = \frac{1}{12} M (a^2 + b^2) \text{ [kg}\cdot\text{m}^2]$		$J = \frac{1}{12} M (4L^2 + C^2) \text{ [kg}\cdot\text{m}^2]$

(2) Moment of inertia of rectilinear motion

General application		$J = \frac{M}{4} \left(\frac{V}{\pi \cdot Ns} \right)^2 = \frac{M}{4} D^2 \text{ [kg}\cdot\text{m}^2]$
Horizontal motion by conveyor		$J = \frac{M}{4} \left(\frac{M_1 + M_2}{2} + M_3 + M_4 \right) 5D^2 \text{ [kg}\cdot\text{m}^2]$
Horizontal motion by lead screw		$J = \frac{M}{4} \left(\frac{V}{\pi \cdot Ns} \right)^2 = \frac{M}{4} \left(\frac{P}{\pi} \right)^2 \text{ [kg}\cdot\text{m}^2]$
Vertical motion by hoist		$J = \frac{M_1 D^2}{4} + \frac{1}{8} M_2 D^2 \text{ [kg}\cdot\text{m}^2]$

(3) Calculation of moment of inertia at different rotating speeds

	$J_\ell = \left(\frac{Ns_2}{Ns_1} \right)^2 J$
--	---

15.0 Miscellaneous

15.2 GD²

(1) GD² of rotating motion

Rotating motion on the center of gravity		Rotating motion off the center of gravity	
	$GD^2 = \frac{1}{2} WD^2$ [kg·m ²]		$GD^2 = W \left(\frac{1}{2} D^2 + 4R^2 \right)$ [kg·m ²]
	$GD^2 = \frac{1}{2} W (D^2 + d^2)$ [kg·m ²]		$GD^2 = W \left(\frac{a^2 + b^2}{3} + 4R^2 \right)$ [kg·m ²]
	$GD^2 = \frac{1}{3} W (a^2 + b^2)$ [kg·m ²]		$GD^2 = \frac{1}{3} W (4L^2 + C^2)$ [kg·m ²]

(2) GD² of rectilinear motion

General application		$GD^2 = W \left(\frac{V}{\pi \cdot N} \right)^2 = WD^2$ [kg·m ²]
Horizontal motion by conveyor		$GD^2 = \left(\frac{W_1 + W_2}{2} + W_3 + W_4 \right) \times D^2$ [kg·m ²]
Horizontal motion by lead screw		$GD^2 = W \left(\frac{V}{\pi \cdot N} \right)^2 = W \left(\frac{P}{\pi} \right)^2$ [kg·m ²]
Vertical motion by hoist		$GD^2 = W_1 D^2 + \frac{1}{2} W_2 D^2$ [kg·m ²]

(3) Calculation of GD² at different rotation speeds

	$GD_i^2 = \left(\frac{N_2}{N_1} \right)^2 GD^2$
--	--

15.0 Miscellaneous

15.3 Warranty

Warranty Period	The warranty period for the Products shall be 18 months after the commencement of delivery or 18 months after the shipment of the Products from the seller's works or 12 months from the Products coming into operation, whichever comes first.
Warranty Condition	<p>In the event that any problem or damage to the Product arises during the "Warranty Period" from defects in the Product whenever the Product is properly installed and combined with the Buyer's equipment or machines, maintained as specified in the maintenance manual, and properly operated under the conditions described in the catalog or as otherwise agree upon in writing between the Seller and the Buyer or its customers; the Seller will provide, at its sole discretion, appropriate repair or replacement of the Product, without charge, at a designated facility, except as stipulated in the "Warranty Exclusions" described below.</p> <p>However, if the Product is installed or integrated into the Buyer's equipment or machines, the Seller shall not reimburse the cost of: removal or re-installation of the Product or other incidental costs related thereto, any lost opportunity, any profit loss or other incidental or consequential losses or damages incurred by the Buyer or its customers.</p>
Warranty Exclusions	<p>Notwithstanding the above warranty, the warranty as set forth herein shall not apply to any problem or damage to the Product that is caused by :</p> <ol style="list-style-type: none"> 1. installation, connection, combination or integration of the Product in or to the other equipment or machine that is rendered by any person or entity other than the Seller ; 2. insufficient maintenance or improper operation by the Buyer or its customers, such that the Product is not maintained in accordance with the maintenance manual provided or designated by the Seller ; 3. improper use or operation of the Product by the Buyer or its customers that is not informed to the Seller, including, without limitation, the Buyer's or its customers' operation of the Product not in conformity with the specifications, or use of lubricating oil in the Product that is not recommended by the Seller ; 4. any problem or damage to any equipment or machine to which the Product is installed, connected or combined, or on any specifications particular to the Buyer or its customers ; 5. any changes, modifications, improvements or alterations to the Product or those functions that are rendered on the Product by any person or entity other than the Seller ; 6. any parts in the Product that are supplied or designated by the Buyer or its customers ; 7. earthquake, fire, flood, sea-breeze, gas, thunder, acts of God or any other reasons beyond the control of the Seller ; 8. normal wear and tear, or deterioration of the Product's parts, such as bearings, oil-seals ; 9. any other troubles, problems or damage to the Product that are not attributable to the Seller.

15.0 Miscellaneous

15.4 Safety Precautions



- Strictly observe the safety rules for the installation place and the equipment to use. (Industrial Safety and Health Law, Technical Standard for Electric Facilities, Extension Rules, Plant Explosion Guidelines, Building Standards Law, etc.)
- Carefully read the maintenance manual before use. If the maintenance manual is not on hand, make a request for one to the distributor from which you purchased the product or to our sales department. The maintenance manual should be sent to the actual user.
- Select an appropriate product that matches the operating environment and usage.
- Install protective equipment on the machine side when the machine is used for transportation of passengers or for elevators, escalators, and dumbwaiters.
- Use an explosion-proof type motor in an explosive environment.
Select an explosion-proof type motor whose specifications is best suited to the danger zone.
- When a 400V-class inverter is used for driving the motor, mount a control filter or reactor on the inverter side or use a sufficiently insulated motor.
- When the machine is used for food processing equipment and others that are susceptible to oil, install an oil pan or other damage preventive devices in case of oil leakage or termination of service life.

15.5 Precautions for applications of special motors

- Explosion-proof motors ... When driving an explosion-proof motor, an explosion-proof verification test is necessary for a motor and an inverter in combination. The same applies to cases where existing explosion-proof motors are driven. Inverters are of a non explosion-proof type. Install them in a safe place.
- Pole change motors ... The rated current is different from that of general-purpose motors. Confirm the max. current of the motor before selecting an inverter. Make sure to stop the motor when changing the number of poles, otherwise the regenerative overvoltage protective circuit or overcurrent protective circuit will be activated, allowing the motor to run free.
- Motors with brake ... Use an independent power supply for the brake. Be sure to connect the brake power supply to the primary side of the inverter, and shut off the inverter output when the brake is activated (when the motor is stopped). Some types of brakes may produce rattling sound during slow-speed running.
- Single-phase motor ... A single-phase motor is not suitable for inverter driving. In the capacitor starting method, the harmonic current flowing through the capacitor may break the capacitor. In motors of a split-phase-start type and arepulsion-start type, the centrifugal switch inside will not be activated, possibly burning the starter coil.

15.6 When driving a 400V-class general-purpose motor by an inverter

- Contact us in cases where a standard motor is driven by an inverter. The withstand voltage of the motor may have to be taken into consideration when a high carrier frequency type (IGBT, for example) inverter that has high input voltage (400V or more) is used or when the wiring distance is long.

Global Contacts

Asia Pacific

SINGAPORE

(Asia Pacific Headquarter)
Sumitomo (SHI) Cyclo Drive Asia Pacific Pte Ltd
Email: inquiry@sumitomodrive.com.sg

15 Kwong Min Road
Singapore 628718
Tel: +65 6591 7800
Fax: +65 6863 4238

AUSTRALIA

Sumitomo (SHI) Hansen Australia Pty Ltd
Email: sales@sumitomohansen.com.au

Sydney (Head Office)
181 Power St, Glendenning, NSW 2761
Tel: +61 2 9208 3000
Fax: +61 2 9208 3050

Brisbane

Unit 11, 20 Archerfield Road
Darra QLD 4076
Tel: +61 7 3853 3800
Fax: +61 7 3375 1000

Central Coast

Suite 3:11, 4 Ilya Avenue, Erina NSW 2250
Tel: +61 2 4365 7500
Fax: +61 2 9208 3050

Melbourne

Unit 2, 88 Henderson Road,
Rowville VIC 3178
Tel: +61 3 9765 4300
Fax: +61 3 9765 4390

Perth

Unit 1/23 Mordaunt Circuit
Canning Vale WA 6165
Tel: +61 8 9456 1766
Fax: +61 8 9456 0944

INDIA

Sumi - Cyclo Drive India Private Limited
Email: sales@smin.sumitomodrive.com

Pune (India Headquarters)

Survey No. 130, Hissa No. 02,
Jeevan Nagar,
Off Mumbai-Bangalore By Pass
Tathawade, Pune - 411033
Tel: +91 -20 -66742900
Fax: +91 -20 -66742901

Ahmedabad

F601, Titanium City Centre, nr. Sachin
Tower, 10 Ft Road, Satellite,
Ahmedabad -380015
Tel: +91 93 7468 8779
Fax: +91 -20 -66742901

Bangalore

105, Prestige Centre Point,
Cunningham Road,
Bangalore - 560052
Tel: +91 -80 -65475758
Fax: +91 20 6674 2901

Chennai

No 76 (Old No C-55)
First Main Road,
Anna Nagar East,
Chennai - 600
Tel: +91 93818 58660
Fax: +91 20 6674 2901

Delhi

532, Somdutt II, Bhikaji Cama Place
New Delhi, DL 110066
Haryana 122 016
Tel: +91 93 1293 9373
Fax: +91 20 6674 2901

Kolkata

Om Tower, Room No.612,
6th Floor, 32, J.L. Nehru Road,
(Chowringhee Road),
Kolkata - 700071
Tel: +91 33 6536 6497
Fax: +91 33 3022 5614

Mumbai

401, Nirma Plaza, Makwana Road,
Marol, Andheri (East),
Mumbai - 400059
Tel: +91 22 2856 3687
Fax: +91 22 2856 3688

INDONESIA

PT. SM-Cyclo Indonesia
Email: inquiry@sumitomodrive.com.sg

Kawasan Industri Lippo Cikarang
Jalan Sungkai Blok F 25No. 09 K
Delta Silicon 3, Lippo Cikarang, Bekasi
Tel: +62 21 2961 2100
Fax: +62 21 2961 2211

MALAYSIA

SM Cyclo (Malaysia) Sdn Bhd
Email: smmasupport@smma.shi.co.jp

Kuala Lumpur (Head Office)
No.7C, Jalan Anggerik Mokara 31/56,
Kota Kemuning, Seksyen 31,
40460 Shah Alam, Selangor D.E. Malaysia
Tel: +60 3 5121 0455
Fax: +60 3 5121 0578

Johor Bahru

24-02, Jalan Ros Merah 2/17
Taman Johor Jaya 81100 JB, Johor
Tel/Fax: +60 7 357 2909

Penang

No. 2945, First Floor, Jalan Prai,
Taman Inderawasih, 13600 Prai, Penang
Tel/Fax: +60 4 390 6386

PHILIPPINES

Sumitomo (SHI) Cyclo Drive Asia Pacific Pte Ltd
Philippines Branch Office
Email: enquiry@smph.sumitomodrive.com

B2B Granville Industrial Complex,
Carmona, Cavite 4116, Philippines
Tel: +63 2-5844921,
+63 46-4303591
+63 46-43820579 - 81
Fax: +63 2 5844922
+63 46-4303592

THAILAND

SM-Cyclo (Thailand) Co., Ltd.
Email: thsales@smcydo.co.th

Bangkok (Sales Office)
195 Empire Tower Unit 2103-4
21st Floor South Sathorn Road,
Yannawa, Sathorn, Bangkok 10120
Tel: +66 2670 0998
Fax: +66 2670 0999

Chonburi (Head Office)

(Assembly and Service Centre)
700/542 Moo 6,
Amatanakom Industrial Estate
Tambol Donhauroh, Muang District,
Chonburi, 20000
Tel: +66 38 454 230
Fax: +66 38 454 235

VIETNAM

Sumitomo (SHI) Cyclo Drive Asia Pacific Pte Ltd
Email: inquiry@sumitomodrive.com.sg

Ho Chi Minh Representative Office
10th Floor, ACB Tower
444A-446 Cach Ming Thang Tam Street,
Ward 11, Dist.3, HCMC
Tel: +84 8 3993 0021
Fax: +84 8 3993 0061

Hanoi

Representative Office
Room 603, NOZA Building
243 Cau Giay Street,
Cau Giay District, Hanoi City
Tel: +84 4 3767 2716
Fax: +84 4 3767 2770

North Asia

JAPAN

(World Headquarter)
Sumitomo Heavy Industries Ltd.

ThinkPark Tower, 1-1
Osaki 2-Chome Shinagawa-ku,
Tokyo 141-6025 Japan
Tel: +81 3 6737 2511
Fax: +81 3 6866 5160

CHINA

Sumitomo (SHI) Cyclo Drive China, Ltd.

Shanghai (China Headquarters)
13 Floor, No.1698 Yishan Rd,
Shanghai, China 201103
Tel: +86 21 3462 7877
Fax: +86 21 3462 7922

Beijing

Room 1806, Tower C, Triumph
Center No.170, Beiyuan Road,
Chaoyang District, Beijing,
China 100101
Tel: +86 10 8485 4688
Fax: +86 10 8485 4698

Guangzhou

Room 1208, A Tower, Centre Plaza,
No.161-163, Linhe West Rd,
Guangzhou China 510620
Tel: +86 20 3828 8422
Fax: +86 20 3828 8580

HONGKONG

SM-Cyclo of Hong Kong Co., Ltd
Unit 1802, 18/F, Park Building,
476 Castle Peak Road, Kowloon,
Hong Kong
Tel: +852 2460 1881
Fax: +852 2460 1882

KOREA

Sumitomo (SHI) Cyclo Drive Korea, Ltd
Royal Bldg, 9F Rm.913,
5 Danju-dong Chongro-ku,
Seoul, Korea 110-721
Tel: +82 2 730 0151
Fax: +82 2 730 0156

TAIWAN

Tatung SM-Cyclo Co., Ltd.
22 Chungshan N. Road,
3rd Sec. Taipei, Taiwan 104,
R.O.C.
Tel: +886 2 2595 7275
Fax: +886 2 2595 5594

Europe

GERMANY

(European Headquarter)
Sumitomo (SHI) Cyclo Drive Germany, GmbH

Cyclostraße 92, 85229 Markt
Indersdorf, Germany
Tel: +49 8136 66 0
Fax: +49 8136 5771

AUSTRIA

Sumitomo (SHI) Cyclo Drive
Germany, GmbH, Austria Branch Office

Gruentalerstraße 30A, 4020 Linz, Austria
Tel: +43 732 330 958
Fax: +43 732 331 978

BENELUX

SM-Cyclo Benelux Office
Paseo Landabari n° 3, 6° B,
48940 Leioa - Vizcaya, Belgium
Tel / Fax: +32 16 60 83 11

FRANCE

SM-Cyclo France SAS
8 Avenue Christian Doppler
Arlington Techniparc,
77700 Serris, France
Tel: +33 164 17 17 17
Fax: +33 164 17 17 18
Fax: +33 164 17 17 18

ITALY

SM-Cyclo Italy Srl
Via dell' Artigianato 23,
20010 Cornaredo (Mi), Italy
Tel: +39 02 9356 2121
Fax: +39 02 9356 9893

SPAIN

SM-Cyclo Iberia, S.L. (SMIB)
Edificio Gobelas, C/Landabari, n°4
Escalera 1, 2° Izqda, Leioa 48940
Vizcaya, Spain
Tel: +34 944 805389
Fax: +34 944 801550

SWEDEN

SM-Cyclo Scandinavia AB

Ridbanegatan 4,
S-21377 Malmö, Sweden
Tel: +46 4022 0030
Fax: +46 4022 0035

UNITED KINGDOM

SM-Cyclo U.K. Ltd.
Unit 29, Bergen Way, Sutton Fields
Industrial Estate, Kingston upon
Hull, HU70YQ, East Yorkshire,
United Kingdom
Tel: +44 1482 790 340
Fax: +44 1482 790 321

America

USA

(American Headquarter)
Sumitomo Machinery Corporation of America

Chesapeake (US Headquarters)
4200 Holland Blvd. Chesapeake,
VA 23323, U.S.A.
Tel: +1 757 485 3355
Fax: +1 757 485 7490

Chicago

175 West Lake Drive, Glendale
Heights, IL 60139, U.S.A.
Tel: +1 630 752 0200
Fax: +1 630 752 0208

Los Angeles

2375 Railroad ST., Corona, CA
92880, U.S.A.
Tel: +1 951 340 4100
Fax: +1 951 340 4108

Louisville

4601 Commerce Crossing, Suite
200, Louisville, KY 40229, U.S.A.
Tel / Fax: +1 502 969 0378

ARGENTINA

SM-Cyclo de Argentina S.A.
Montes de Oca #6719,
(B1606BMG) Munro, Buenos Aires,
Argentina
Tel: +54 11 4765 5332
Fax: +54 11 4765 5517

BRAZIL

SM-Cyclo Redutores Do Brasil, Com. Ltda.
Av. Fagundes Filho, 191 Metro Sao Judas
Edificio-Sala H123 Sao Paulo-SP
Brasil 04304-010
Tel: +55 11 5585 3600
Fax: +55 11 5585 9990

CANADA

SM-Cyclo of Canada, Ltd.
1045 South Service Road West,
Oakville, Ontario, Canada L6L 6K3
Tel: +1 905 469 1050
Fax: +1 905 469 1055

CHILE

SM-Cyclo De Chile, Ltda. (SMCH)
San Pablo N3507, Comuna de
Quinta Normal, Santiago, Chile
Tel: +56 2 892 7000
Fax: +56 2 892 7001

MEXICO

SM-Cyclo De Mexico, S.A de C.V.
Av. Desarrollo No. 541, Parque
Industrial Finsa Guadalupe, NL,
Mexico CP 67114
Tel: +52 81 8144 5130
Fax: +52 81 8369 369

www.sumitomodrive.com