

Sumitomo Drive Technologies

Our extensive SEA and Australia network offers customers a wide regional support network. From inventory distribution to manufacturing to assembly, we have the team to ensure high quality, responsiveness, on-time delivery, and quick lead times.

- ★ Asia Pacific Headquarters
- ★ Manufacturing Hub
- Assembly & Service
- Service
- ▲ Regional Sales Office

Asia Pacific Corporate Profile

Product Showcase



Our History

Our Brand

Sumitomo Drive Technologies

The Sumitomo Group began more than 400 years ago when Masatomo Sumitomo opened a book and medicine store in the city of Kyoto, Japan. Over the next 100 years, the Sumitomo family developed a leading presence in copper refining, which led to the family opening the Besshi Copper Mine. The Shikoku Besshi Copper Mine first opened in 1691, it was developed on the lopes of the Akaishi Mountain range in Ehime Prefecture. The mine operated for 283 years and substantially underpinned Sumitomo's development.

In 1888, a company was formed to provide equipment repair services to the Besshi copper mine. Almost 50 years later, **in 1934**, the company was incorporated as Sumitomo Machinery Co., Ltd. to manufacture machinery for the steel and transportation industries to support rapid economic growth.

In 1969, Sumitomo Machinery Co., Ltd. merged with Uruga Heavy Industries Co., Ltd to create Sumitomo Heavy Industries, Ltd. The company continues to innovate and expand to meet the demands of new market frontiers. Today, Sumitomo Heavy Industries manufactures injection modling machines, laser systems, semiconductor machinery and liquid Crystal production machinery.

In 1939, Sumitomo Heavy Industries started manufacturing Cyclo® Drives with technical collaboration with CYCLO Getriebebau Lorenz Braren KG of Germany. This marks the birth of Sumitomo Drive Technologies.

In 2003, "Sumitomo Drive Technologies" was officially launched by Sumitomo Heavy industries as a global brand name to bind its power transmission business. Since then, Sumitomo Drive Technologies continues to lead the world in knowledge and innovation in power transmission and control devices.

Why Sumitomo

Our business continues to grow and expand. Over the years, the business has expanded to included Hansen Industrial Gearboxes, Seisa and Invertek Drives. We are well established and offers a diverse range of products and engineered solutions to a wide range of industries.

Devoted to Quality

In addition to one of the most comprehensive product lines of any power transmission company, we offer the most reliable and highest quality products available in the industry. Whether it's product development or manufacturing processes, our Quality culture resonates through our entire global network.

Committed to our Employees and the Community

We recognize our employees are our most valuable asset. They are the driving force behind our innovative products, our ability to support our customers, and our commitment to continuous process improvement. We strive to be a valuable member of society and take pride in the contributions we make to our communities across Australia and New Zealand.

Life Cycle Services and Repair

We offer an extensive range of services and repair options for all Sumitomo gear units and drive assemblies, extending to other brands as well. We have you covered throughout your customer journey with us. Our factory trained technicians ensure that Sumitomo Hansen's strict quality and build standards are adhered to during the repair process.

Dedicated to Innovative Manufacturing

With near to a century of expertise in manufacturing, our global capabilities are unmatched in the industry. We have manufacturing and assembly facilities on every continent and continue to make investments in our manufacturing technologies to maintain our position as a leader in innovation and solutions.

Complete Solutions for various Industries

Sumitomo has a long history of strong partnerships with suppliers and end users across various industries. Together, with Invertek, Hansen, Seisa and many other brands under us, we are able to offer a wide range of Gear Drive Packages to comply with the most demanding applications.

Global Manufacturing and Sales Support

Our range of products are supported, no matter where in the world they are installed. Factories in Vietnam, Japan, China, North and South America and Europe ensure supply to all parts of the globe. There are more than one hundred sales offices located throughout the world, including the support of local build centres, to ensure you have the technical and spare parts backup should the need arise.

Creating a Fair and Better World

inspired by the values of
sustainable development

Our Corporate Social Responsibility

We are all guardians of the planet and environment that we live and work in. As individuals and businesses we have a responsibility for its current and future sustainability.

Our mission is to contribute to solving social, environmental, and industrial problems through the development and optimization of drive technologies.

We are doing this through our commitment to sustainability via the goals of People, Planet and Prosperity to realise the vision of global economic, social and environmental sustainability.



Planet

We are one world socially, economically, and environmentally. Our mission is to safeguard it for future generations through the development of sustainable systems and technology.

Prosperity

We will support the development of prosperity and success for all through responsible and sustainable means.

People

Our aim is to create a sustainable and inclusive environment, socially and economically, for all.

EcoVadis Silver Rating



SHI received a Silver Rating in its latest Sustainability Assessment by EcoVadis, an international ratings provider.

Sustainability, the environment and our responsibility

As a business, we have a responsibility for the sustainable and fair future of our communities. Solving social and environmental issues is a duty of our generation. Sumitomo Heavy Industries, Ltd (SHI) and our people, products, and services play a crucial part in this.



We offer a comprehensive lineup of high quality power transmission products.

For any of your power transmission needs, we have the right product for you.

Robust, Reliable, Efficient

No Matter the Application



C CYCLO® 6000

- Up to 175 kW
- 14mm to 180mm (Solid Shaft)
- Up to 68,130 N·m
- 3:1 up to 658,503:1

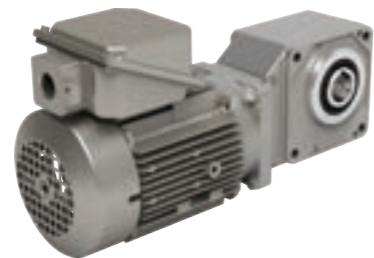

H HYPONIC®

- Up to 11 kW
- 15mm to 55mm (Hollow & Solid)
- Up to 1,480 N·m
- 5:1 up to 1,440:1



B4 CYCLO® BBB 4

- Up to 75 kW
- 55mm to 120mm (Hollow & Solid)
- Up to 18,076 N·m
- 11:1 up to 26,000:1 and greater



SM SMmotor

- IE3 Efficiency
- Up to 55kW in stock
- IP66, X15 Orange in stock
- Foot and Flange Types



HB CYCLO® HBB

- Up to 30 kW
- 40mm to 100mm (Hollow Bore)
- Up to 8,564 N·m
- 11:1 up to 26,492:1



HS HELICAL Shaft Mount

- Up to 224 kW
- 015 to 608 (Hollow Bore)
- Up to 43,938 N·m
- 5:1, 13:1, 20:1, 25:1



INVERTEK E3 & P2

- Up to 250 kW
- 200 to 600V
- Up to 200% Overload (4 secs)
- P2: Up to 200% (From Zero Speed)

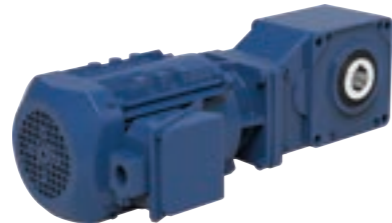

BH BBB-H

- Up to 11 kW
- 40mm to 55mm (Hollow)
- Up to 1,020 N·m
- 5:1 up to 20:1

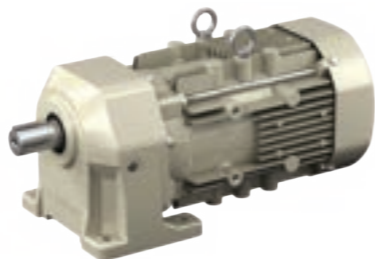

P PREST® NEO

- Up to 2.2kW
- Up to 1230N·m
- 3:1 up to 200:1

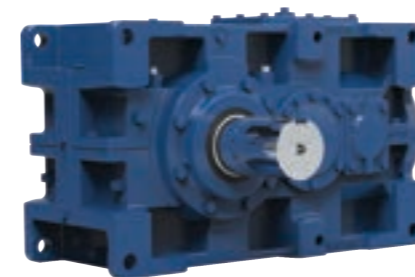

PX PARAMAX® 9000

- Up to 3,900 kW
- 58mm to 360mm (Hollow & Solid)
- Up to 552,000 kN·m
- Up to 500:1 Standard



P4 HANSEN P4

- Up to 10,500 kW
- 80mm to 400mm (Solid Shaft)
- Up to 1.1m N·m
- Up to 630:1 (and custom ratios)



S SEISA

- Up to 61,000kW
- Up to 54,000rpm
- ~5,000,000 N·m and more



Helical Shaft Mount

Provides a simple and convenient equipment interface by mounting directly on the drive shaft. Uses our patented Taper-Grip® Bushing for quick reducer mounting and removal.

Torque: Up to 43,938 N·m
Ratio: 5:1, 13:1, 20:1, 25:1
Power Rating: Up to 224 kW



Couplings

Complete line of couplings for a wide range of applications. All couplings are manufactured to the highest specifications, and meet the most rigorous material specifications.

Torque: Up to 6.4m N·m
Bore Size: Up to 900mm
Type: Flexible, Grid and Disc



Altax®

Using our Cyclo® technology, the exceptionally robust Altax® line is compact and low noise. All models are maintenance free with grease lubrication. Altax® caters to a broad range of applications.

Torque: Up to 458 N·m
Ratio: Up to 1,003:1
Power Rating: Up to 3.7 kW



Custom Gear Drives

Custom Mill, Planetary, and High-Speed Drives available in a wide range of configurations. Tough, compact, and application specific designs for unique applications including API requirements.

Torque: Up to 736,000 N·m
Ratio: Up to 1,400:1
Custom ratios available

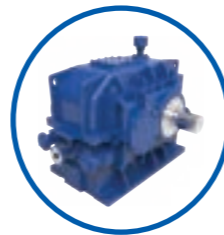

Variators

Beier® Variator offers mechanical stepless speed control with high capacity and long life. Ideal for low horsepower, high torque applications requiring variable speed such as packaging machines.

Torque: Up to 68,200 N·m
Speed Range: Up to 10:1
Power Rating: Up to 150 kW



Additional Services



Online product configurator streamlines the selection process, enabling *you* to build our power transmission products for your specific application.
www.SumitomoDrive.com/Configurator

- "H" Foot
- V-Flange
- F-Flange



MOUNTING

- Top Mount
- J Adapter
- Free Shaft
- Shovel Base
- C-Face Motor
- Integral Motor
- X Adapter



INPUTS

SEALS

Wear sleeves and pressure-rated to prevent leaks.

HOUSING

Rugged, shock-resistant cast iron housing. Optional ductile iron housing also available.

RING GEAR HOUSING

High power density, all reduction contained in compact ring gear housing.

500% MOMENTARY SHOCK LOAD

The Cyclo® design spreads the load across 2/3 of the reduction components, enabling the units to absorb and dissipate shocks better than typical concentric drives.

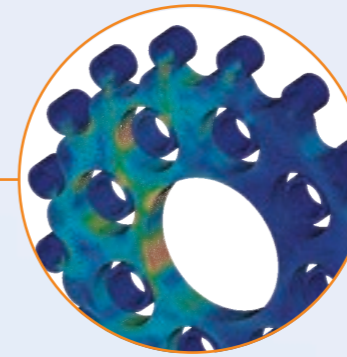

CYCLO® DISC

All rotating components are fully hardened, vacuum degassed bearing-grade steel, for consistent, reliable performance.

DYNAMIC AIR MOTIVATOR

MOTIVATOR COVER

OIL LEVEL INDICATOR

SLOW-SPEED SHAFT

ECCENTRIC CAM

HIGH-SPEED SHAFT

CYCLO® 6000

UNMATCHED RELIABILITY & EXCEPTIONAL PERFORMANCE

Cyclo® speed reducers and garmotors are the **premier in-line drives**. The revolutionary Cyclo® design provides **quiet, efficient, and reliable** performance exceeding that of involute tooth gear designs.

Unlike geared designs, the Cyclo®'s reduction components operate in compression rather than shear, which results in exceptionally rugged and **shock resistant performance**.

The Cyclo® technology coupled with innovative product options and accessories offer the most extensive range of application solutions available.

OPTIONS



Overhead Drive



Extended Base

SPECS



POWER RATING
Up to 175 kW



DIAMETER
14mm to 180mm
(Solid Shaft)



TORQUE
Up to 68,130 N·m



RATIO RANGE
3:1 up to 658,503:1

• Foot Mount • Torque Arm • Flange



MOUNTING

• Plug-In-Shaft • Shrink Disc



• Keyed Hollow Bore • J Adapter

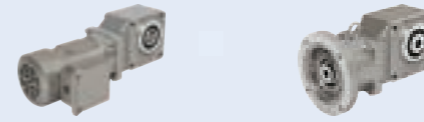

• X Adapter



• Integral Motor



INPUTS & OUTPUTS

QUALITY HOUSING

Aluminum housing is lighter and increases thermal rating.

ALL-STEEL HYPOID GEARING

Patented Hyponic® gear technology is up to 93% gear efficient across all ratios providing a smooth, quiet operation which does not require a cooling fan.

SEALS

Multiple lip, harsh duty, and food-grade designs available to prevent leaks.

HYPOID PINION

Single-piece all steel hypoidal pinion for longer life. Lasts millions of cycles without measurable wear.

QUILL O-RING

Prevents water intrusion.

DUAL BEARING SUPPORT

DUAL BEARING SUPPORT

C-FACE QUILL

Supported by two bearings for long life, the quill style motor adapter allows for maximum motor flexibility.



REQUIRES NO OIL CHANGES AND UP TO 93% EFFICIENT

The Sumitomo Hyponic® gearing represents over 25 years of hypoid gearing excellence. With millions of Hyponic® units currently in service, the product features a compact, modular housing, maintenance-free grease lubrication and boasts a gear efficiency of up to 93% across all ratios.

The maintenance-free grease lubrication enables the unit to be mounted in any orientation without custom modifications. In addition to general-purpose solutions, with multiple food grade options, Hyponic® is perfect for harsh, high-pressure wash-down environments.

Simplify your gear drive assembly and increase efficiency by switching to Hyponic®.

SPECS



POWER RATING
Up to 11 kW



DIAMETER
15mm to 55mm



TORQUE
Up to 1,480 N•m



RATIO RANGE
5:1 up to 1,440:1



MOUNTING



INPUTS & OUTPUTS

DUCTILE IRON HOUSING

Twice as strong as cast iron, making it one of the most rugged bevel gearboxes on the market.

OPTIONAL TACONITE SEAL ASSEMBLY

Heavy-duty, fortified, grease purgeable system withstands the most demanding applications.



ONE PIECE PINION

Oversized, single-piece pinion provides a robust solution capable of 300% momentary shock-load. Designed and manufactured in the USA.

100% HARDENED STEEL COMPONENTS

Provide long life, smooth operation, and superior strength.

TAPERED BEARINGS

Resist axial and radial loads simultaneously.

TANDEM DUAL LIP SEALS

Prevent leaks and exclude contaminants.

BEARING

CYCLO® DISC

All rotating components are manufactured from fully hardened, vacuum degassed bearing-grade steel, for consistent, reliable performance.

B4 CYCLO® BEVEL BUDDYBOX® 4

RIGHT ANGLE SPIRAL BEVEL WITH CYCLO® OR PLANETARY INPUTS

A robust, state-of-the-art, mid-sized family of speed reducers and gearmotors. The Cyclo® BBB4 has a unique combination of features that result in a **highly reliable, efficient, and durable gearbox**. The all-steel internal construction, Cyclo® or planetary gear inputs and the ductile iron housing, provide **unmatched ruggedness**.

Also available as a **mixer drive** with an **integrated drywell** and space-saving footprint.



SPECS



POWER RATING
Up to 75kW



DIAMETER
55mm to 120mm
(Hollow & Solid)



TORQUE
Up to 18,076 N·m



RATIO RANGE
11:1 up to 26,000:1
and greater

- Flange Mount
- Face Mount
- Hollow Shaft



MOUNTING

- Keyed Hollow Bore
- Taper-Grip® Bushing
- Gearmotor
- J Adapter
- X Adapter



INPUTS & OUTPUTS

LONG LIFE BEARINGS

Oversized, heavy-duty bearings for maximum strength and service life.

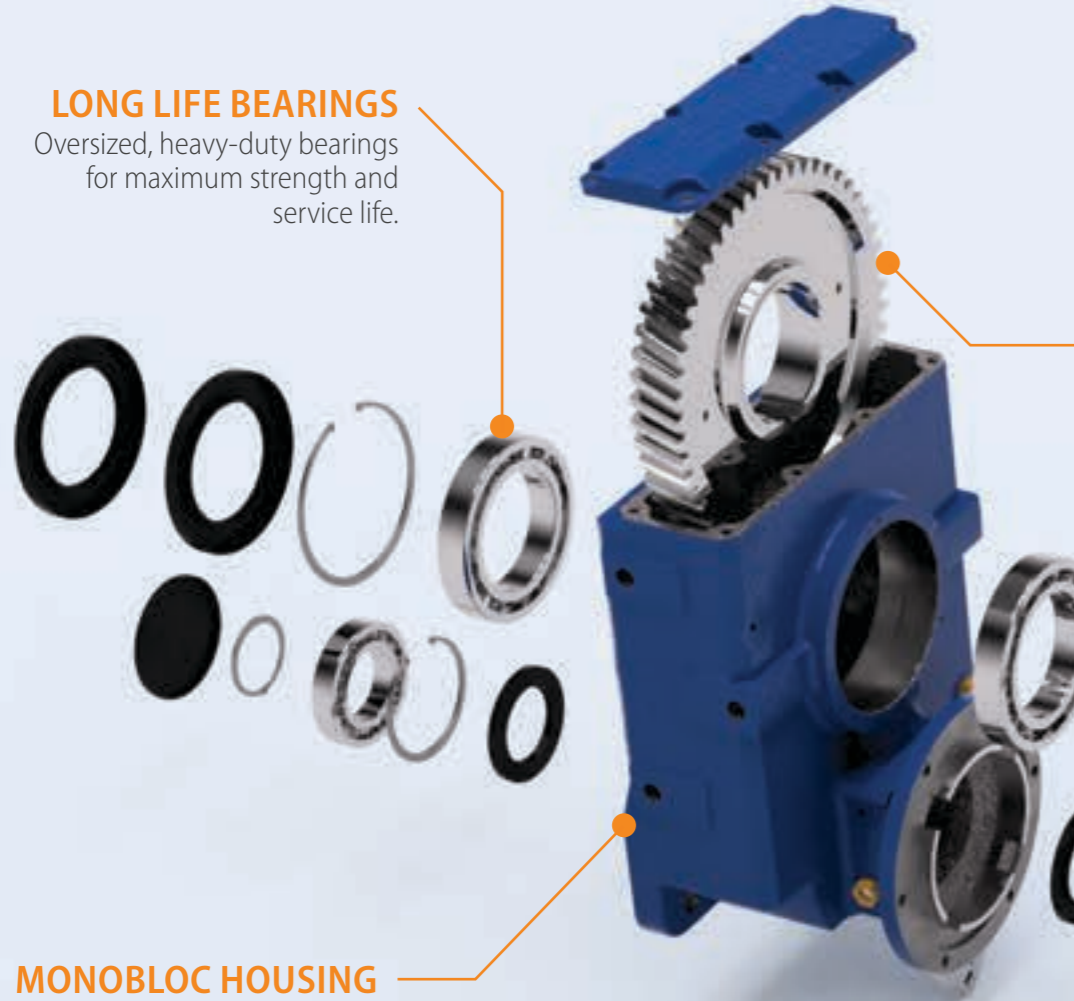

MONOBLOC HOUSING

Cast iron housing is strong, corrosion resistant, and sound dampening. Monobloc design eliminates leaks at housing split.

CYCLOIDAL TECHNOLOGY

Utilizes all Cyclo® input modifications to produce high ratios in amazingly small spaces.

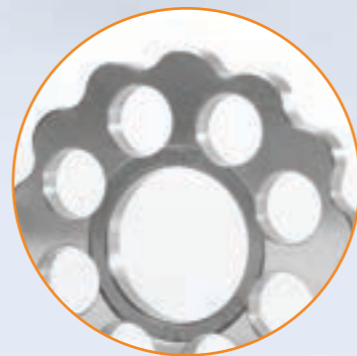

HELICAL GEARING

Hardened-steel gearing.

DOUBLE OUTPUT SEALS

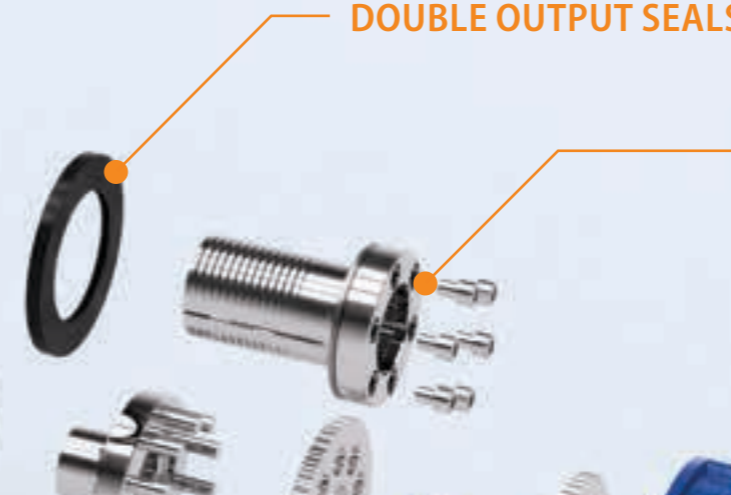

TAPER-GRIP BUSHING®

Our patented Taper-Grip® bushing system offers simple shaft mounting and provides self-aligning, backlash-free torque transmission to the driven shaft.

HIGH SPEED SHAFT

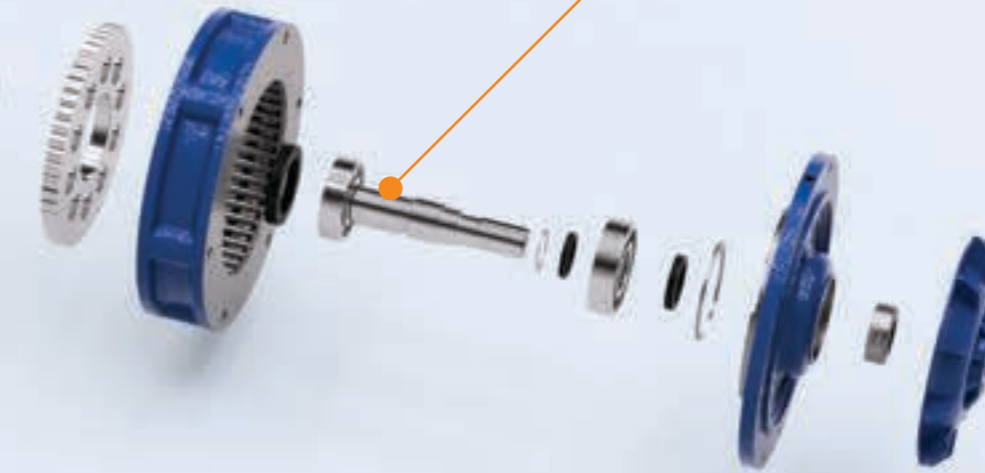

HB CYCLO® HELICAL BUDDYBOX®

INNOVATIVE SHAFT MOUNTED DRIVE SOLUTIONS FOR DEMANDING APPLICATIONS

The Cyclo® HBB combines the **quiet, efficient, and reliable** performance of the Cyclo® input with the **rugged helical gear output**. The modular design provides a compact, efficient product and the most flexible range of output speed and torque combinations available.

The simple splash lubrication system extends the life of the unit and the highly efficient design has **no thermal limitations** which eliminates the need for an external fan.

SPECS



POWER RATING
Up to 30 kW



DIAMETER
40mm to 100mm
(Hollow Bore)



TORQUE
Up to 8,564 N·m



RATIO RANGE
11:1 up to 26,492:1

- Toruqe Arm
- Flange Mount
- Face Mount



MOUNTING

- X Adapter
- J Adapter
- Shrink Disc
- Keyed Hollow Bore
- Gearmotor



INPUTS & OUTPUTS

HARDENED STEEL GEARING

QUALITY HOUSING

Aluminum housing is lighter and increases thermal capacity.

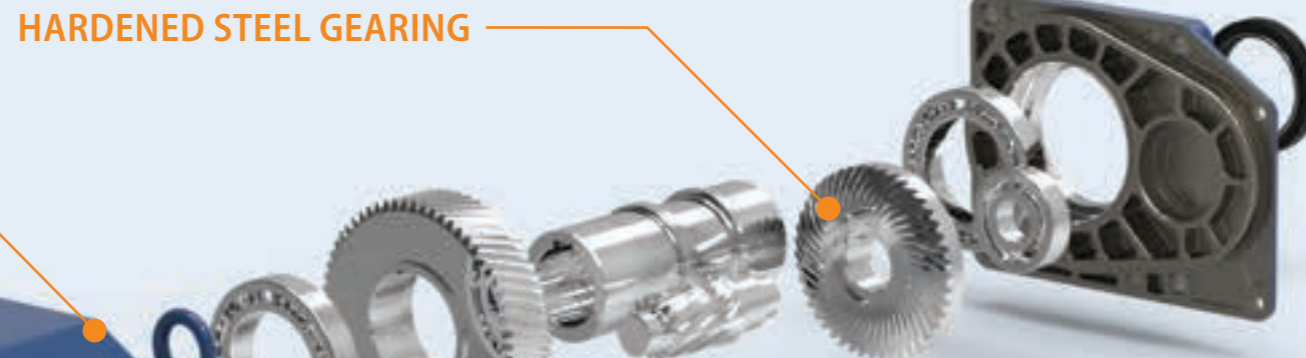

BEVEL PINION & HELICAL GEARING

A combination of power and speed. Up to 97% gear efficient across all ratios providing a smooth, quiet operation which does not require a cooling fan.

SEALS

Multiple lip, harsh duty, and food-grade designs available to prevent leaks.

BEVEL PINION

Single-piece all steel bevel pinion for longer life. Lasts millions of cycles without measurable wear.

BH BEVEL BUDDYBOX® H SERIES

EXTREMELY EFFICIENT AND COMPACT WITH LOW REDUCTION RATIOS

The combination of a **Bevel Input** and a **Helical Output** make this unit **extremely efficient** with the capacity for input speeds up to 3,600 rpm. Dependable **hardened steel gearing** inside a **lightweight, compact housing** allows for **easy installation** with less load on the head shaft. Aluminum construction provides **high thermal capacity**.

The **maintenance-free** grease lubrication enables the unit to be mounted in any orientation without custom modifications. The **greater efficiency** of the BBB-H allows for use of a **smaller motor**, resulting in the same performance with much **lower operating costs**. Its **power** and **speed** make this unit perfect for airport baggage handling and general conveying applications.

SPECS



POWER RATING
From 0.75-4.0kW



DIAMETER
35,45,55mm
(Hollow Bore)



TORQUE
Up to 1,020 N·m



RATIO RANGE
5:1 up to 20:1



- Immersion Heater
- Creep Drive
- Heavy Duty Anti-Dust Breather



ACCESSORIES

- Solid Shaft
- Shrink Disc
- Keyed Hollow Bore



OUTPUTS

SPLIT HOUSING

Standard in large frame sizes to allow easy maintenance. A large inspection port provides a window for gear inspection. Available in standard gray cast iron with ductile and fabricated steel options.

TACONITE SEAL

This option features a dual-layer oil and grease sealing system.

SLOW SPEED SHAFT

CASE CARBURIZED & GROUND GEARING

High precision carburized gearing with a 25° pressure angle offers a thicker dedendum and higher strength ratings than the typical 20° pressure angle.

HIGH TENSILE SHAFT

Strong shaft material optimized for extended operation in rugged environments.

TIER 1 SUPPLIER ROLLER BEARING

High capacity bearings increase load capacity without increasing lead-time. Tapered, double-row spherical, or cylindrical roller bearings depending on size and configuration.

PX PARAMAX® 9000

PARALLEL & RIGHT ANGLE LARGE INDUSTRIAL GEARBOXES

Paramax® parallel and right angle drives are some of the largest and most durable power transmission systems operating in the world. The series features double, triple, quadruple reduction gearboxes, global standardization and availability, and support from our worldwide facilities.

Optional accessories: Backstops, Motor Mount Options, Seal Upgrades, Heating & Cooling and Lubrication Solutions, Paint Upgrades, Storage and Packaging Options, and Complete Drive Package Solutions.

DRIVE PACKAGE



SPECS



POWER RATING
Up to 3,900kW



DIAMETER
58mm to 360mm
(Hollow & Solid)



TORQUE
Up to 552 kN·m



RATIO RANGE
Up to 500:1
Standard

- Vertical
- Horizontal
- Single-Stage



VARIATIONS

- Hollow Shaft - Shrink Disc
- Normal Solid Shaft
- Hollow Shaft - Keyed
- Oversized Solid Shaft
- Extended Bearing Housing

VERTICAL SHAFT OPTIONS

- Extended Bearing
- Pilot or Flange Mount
- Hollow Shaft



OUTPUTS

SPLIT HOUSING

Rugged, split housing for horizontal and vertical applications. Round housing tops help keep the unit free from debris.

GEARS

High torque geometry in low-speed gears. Low-noise geometry in high-speed gears.

PINION SHAFTS

Rigid standardized pinion shafts and housings for better lateral load distribution.

SLOW-SPEED SHAFT

Shaft projections include captured keyways with rounded end key inserts to eliminate stress concentrations.

INTERNAL HOUSING

Exceptional construction ensures bearings are lubricated at start-up to maximize reliability and life.

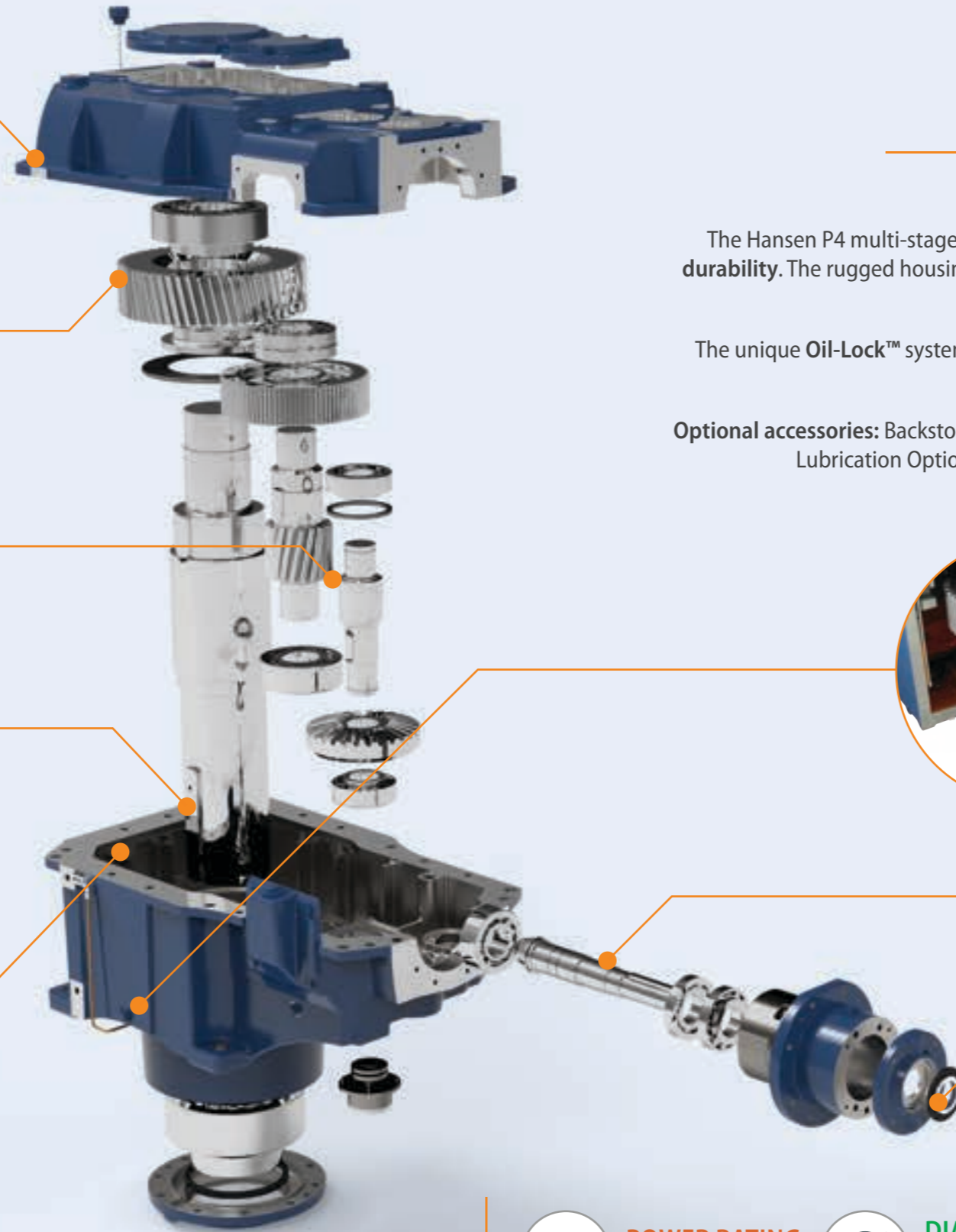

P4 HANSEN P4

REMARKABLE POWER AND PERFORMANCE WITH LOW NOISE

The Hansen P4 multi-stage gear unit is **market leading in quality and technology**, excelling in **reliability and durability**. The rugged housing, along with our commitment to innovating state-of-the-art technology, provides remarkable **power and performance**.

The unique **Oil-Lock™** system offers a **maintenance-free** seal on high speed shaft extensions, designed to keep the oil in and dirt out.

Optional accessories: Backstops, Motor Mount Options, Multiple Sealing Upgrades, Various Heating, Cooling, and Lubrication Options, Heavy Duty Paint or Packaging Options, and Complete Drive Package Solutions.

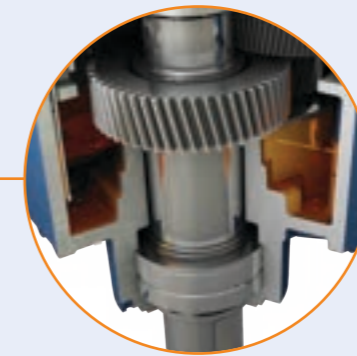

INTEGRATED DRYWELL

Cast into 3 and 4 stage vertical housings mean this option provides a truly leak-proof low-speed shaft.

HIGH-SPEED SHAFT

Extra long high-speed shaft projections suitable for interference-free coupling connections.

MAINTENANCE-FREE OIL-LOCK®

Standard high-speed seal arrangement.

OPTIONS



UniMiner
Flippable housing and horizontal split line make the ideal alignment-free drive package for mining

SPECS



POWER RATING
Up to 10,500 kW



DIAMETER
80mm to 400mm
(Solid, Heavy-Duty, and Hollow)



TORQUE
Up to 1.1 million N·m



RATIO RANGE
Up to 630:1 (Custom ratios available)

OPTIDRIVE E3

GENERAL PURPOSE DRIVE

Compact, robust, and reliable general purpose drive.

Focused on ease of use, Optidrive E3 provides unrivaled simplicity of installation, connection, and commissioning, allowing the user to benefit from precise motor control and energy savings within minutes.

Available in IP66/Nema 4X outdoor rating with tough polycarbonate plastics specifically chosen to withstand degradation by ultraviolet (UV), greases, oils, and acids. Also, robust enough not to be brittle at -20°C (-4°F).

 Compliant with international standards.



ENCLOSURES

- 150% Overload for 60 secs
- 175% Overload for 2.5 secs
- 98% Typical Efficiency

FAST CONNECTION

5mm rising clamp terminals with captive screws.

KEYHOLE MOUNTS

QUICK REFERENCE

Integrated help card.

OPTISTICK SMART

Rapid Commissioning Tool that allows copying, backup, and the restoring of drive parameters.



DUAL ANALOG INPUTS



INTEGRATED DISPLAY

LED or multi-language text display.

INTEGRATED CABLE MANAGEMENT

PLUGGABLE CONTROL TERMINALS

FANS

High quality long-life fans.

OPTIDRIVE P2

HIGH PERFORMANCE DRIVE

High-performance variable frequency drive for standard induction and permanent magnet motors.

A user-friendly interface and high performance make it perfect for tackling the most demanding applications smoothly.

Extensive I/O and communications interface capabilities ensure the drive can be integrated quickly and efficiently into a wide variety of control systems.

Dedicated Hoist Mode Operation with motor holding brake control make it perfect for marine and applications.

SPECS



POWER RATING
Up to 250 kW



POWER OPTIONS
Single-Phase: 200-240V
3-Phase: 200-600V



TORQUE
Up to 200%
(From Zero Speed)

• 200% Overload for 2.5 secs

• 98% Typical Efficiency

• Integral Brake Transistor

Retro-Fit units with transition bases allow us to match your existing footprint.

Custom drop-in units made to match existing unit's critical dimensions.

Retro-Fits and Drop-Ins

Whatever your requirements, we have a solution for you. Sumitomo Drive Technologies offers customized bases which allow our units to match the footprint of an array of existing applications and drop-in gear drives to upgrade and replace competitor units.

With a wide range of options, our engineers can replace your unit with minimum impact while delivering a premier product with performance and reliability.



Scan for our drop-in webinar video

Retro-Fit

Match existing footprint

A custom transition base will position the new low-speed shaft to be in the EXACT same position as the original low-speed shaft. Our retrofits provide an excellent balance between the cost savings of a standard gearbox and the benefits of minimal on-site modifications.

Typically, only relocating the motor mount is required for this option. We offer motor mounting options to help minimize the impact of relocating the motor mount, such as flanged motor adapter for c-face or d-flange motors.

Options might include a special low-speed shaft diameter or length and motor lantern.

The red circles in the diagram represent the existing bolt pattern of a customer's unit. The transition base is fabricated to match the height, ensuring alignment of the low-speed shaft to the machine shaft.

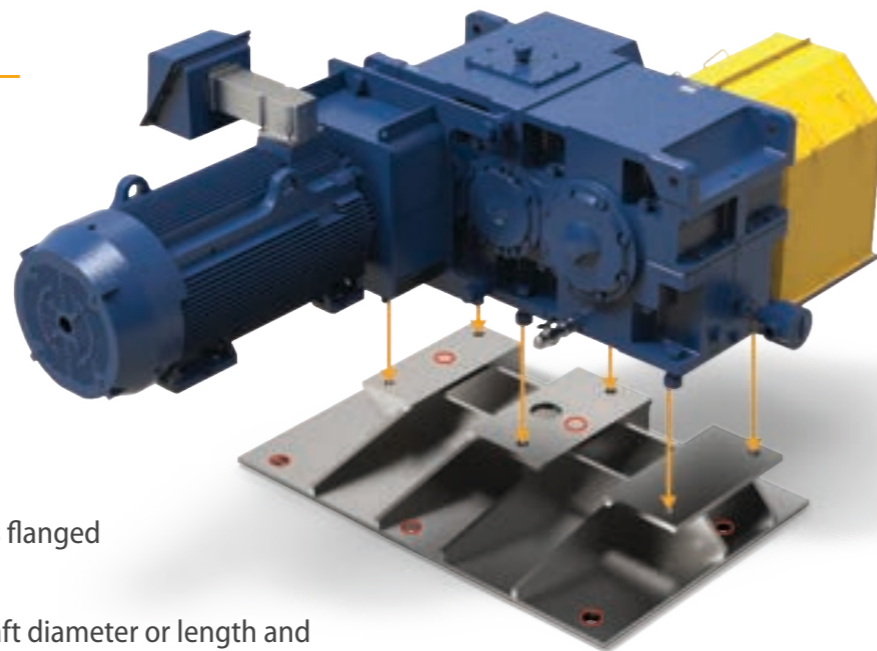

Drop-In

Match existing unit's critical dimensions

With downtime being such a critical factor in your operation, let us install one of our custom drop-in units.

Installation-ready units are designed specifically to drop-in to existing applications with ease. Our expert engineers understand that on-site modifications or re-engineering your system is not always an option.

These stress-free units can have your application back up and running in no time. We offer fabricated steel housings, custom baseplates, custom gearing and shafting and more!

This product will literally drop-in to place; same footprint, same shaft positions!

Specialty Units

For non-standard gearing and custom ratios, we offer special customized units to fit in any application. From custom paint to intricate gearbox lubrication systems, our team of engineers will make sure all of your custom gearbox needs are met.

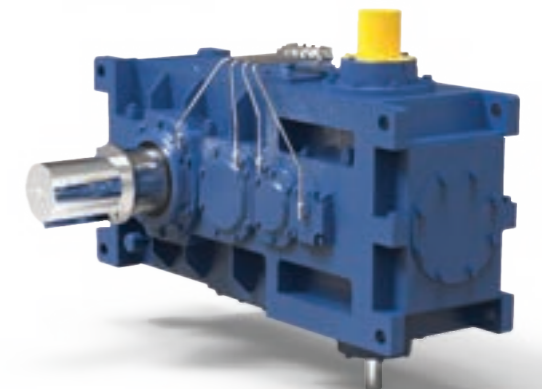
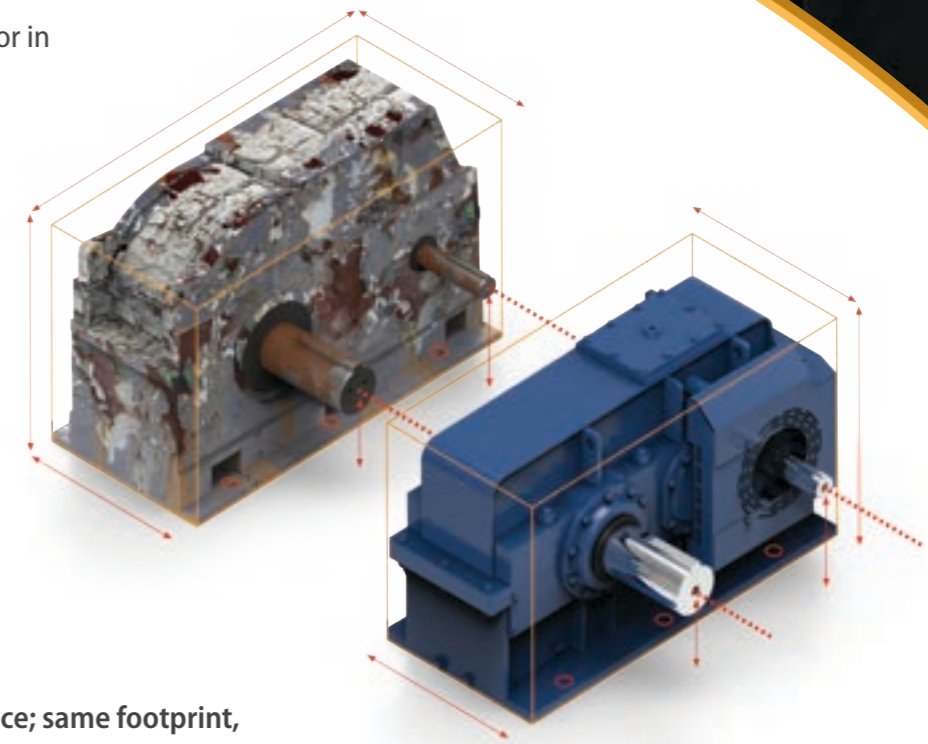

Our factory capabilities support all of your gearbox & gearmotor needs

Connect with us

Aftermarket

Our personnel are the industry's most versed gearbox problem solvers. We provide both standard and tailored services, for maximum gearbox life.

Experts in Service

Global Support, Local Service

With a vast network of engineers and gearing experts, there is no problem we can't handle.

In addition to our extensive network, our Manufacturing and Services provides unmatched capabilities and expertise in the area of custom gearbox repair and service. No gearbox is too big for us to handle.

Whether custom gear manufacturing or on-site gearbox repair, let our team keep your operation running.

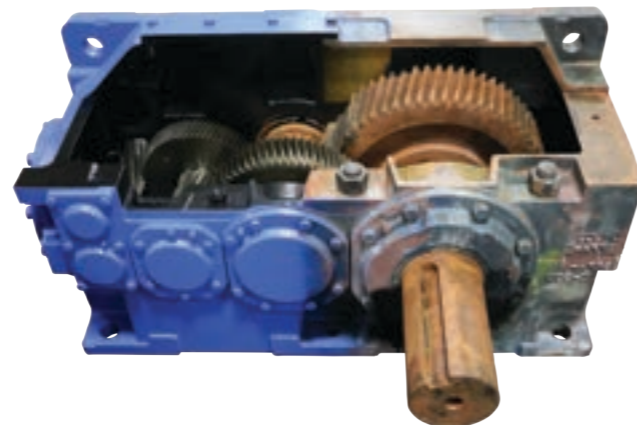

Repairs

Scheduled & Emergency Repair

Repair services for all your related gearbox needs and 24-72* hour turnaround to the original factory specifications and warranty using Sumitomo-manufactured parts.

Extended warranty programs are available upon request.

Root Cause Investigation

Product Support

Apply a wide range of approaches, tools and techniques to uncover the causes of your problems.

Field Services

For Your Convenience

Most of the services offered and customized training can be performed on location.

Scan us

Our various platforms offers informative information for your various needs and knowledge. Learn more about our product? Download our available resources? Or simply connect with us both online or offline? Scan them here any time.



SumiShowcase
Interactive Showcase



Website
One-stop information
and more about us



Product Collaterals
Brochures, catalogues,
manuals and flyers



Tradeshows
Upcoming APAC
Tradeshows

Social Media

Connect with us on our social media pages



YouTube



LinkedIn



TikTok

web: SumitomoDrive.com

✉ Enquiries for Singapore, Vietnam, Indonesia: marketing@sumitomodrive.com.sg Thailand: thsales@smcyclo.co.th
Philippines: sca.smph-enquiry@shi-g.com Malaysia: smma.support@shi-g.com Australia: shau.sst@shi-g.com

Worldwide Facilities

Worldwide Manufacturing Operations

As a global leader of power transmission and control, Sumitomo Drive Technologies have established manufacturing facilities at strategic locations worldwide to cater to our customers needs.

• Japan - Ohbu



The State-of-the-art facility near Ngoya is the manufacturing centre for our flagship Cyclo® Drives, Beier® Variators, High Precision Gears and all geared motors. The R&D Centre is equipped with extensive product performance testing laboratories and is continuously developing products to meet our customer's requirements.

• Japan - Osaka



SEISA Gears Ltd, a wholly owned subsidiary of SHI, is a merger between Osaka SEISA Chain Manufacturing Ltd and SKK UEDA Gears, Ltd. This facility in Osaka manufactures Planetary, Helical and Bevel gears for cement, coal, steel, power, turbines, pumps and other industries, usually in the range of Mega Newton-meter torque capacity. Couplings and SKK range of geared products are also manufactured here.

• Japan - Okayama



This facility is the manufacturing hub for our Paramax®, Helical and Bevel gearboxes as well as other special gear products. It is responsible for the design and development of not only standard drives such as cooling tower drives, extruder drives, crane drives etc. Custom-built gearboxes are also developed and manufactured here.

• Belgium - Edegem



Sumitomo Heavy Industries Ltd acquired Hansen Industrial Gearboxes NV (HIT) in 2011. Hansen, a renowned industrial gearbox designer and manufacturer since 1939, has a strong in-house R&D operations maintaining HIT's technological leadership in industrial gearboxes. This facility in Edegem continues to manufacture Hansen® gears and gearboxes serving a wide range of industrial applications throughout the world.

• Vietnam - Hanoi



Established in 2005, this is the sixth manufacturing plant outside Japan. Strategically located in the growth region of South East Asia, the plant supplements our supply chain system by ensuring uninterrupted supply of small gearmotor products (Hyponic®, Prest Neo, Altax® etc) and electric motors to our sales and assembly facilities around the world.

• China - Tangshan



Sumitomo Heavy Industries (Tangshan), Ltd. caters to the growing Asia region since 2009. Situated in an area of 100,000 square meters, this facility is the base for development, production, sales and after-sales for Paramax®, Helical and Bevel gearboxes, Compower® planetary gearboxes and other SEISA products. All manufacturing processes are controlled in-house with Japanese experts ensuring quality products and services.

• Germany - Munich



Sumitomo's European operations have their roots in Germany when in 1931, the inventor of CYCLO® speed reducers, Lorenz Braren, formed Cyclo Getriebebau GmbH. This facility in Munich is both a manufacturing facility and a Research and Development centre in Europe.

• USA - Chesapeake



This facility in Chesapeake is a manufacturing hub for the North American markets. Together with other assembly and stock facilities in the USA, Canada and Mexico, this hub strive to remain the market leader in the Americas.

• Brazil - Itu



This \$83million futuristic facility in Itu, a major industrial area in São Paulo, Brazil, manufactures and assembles Paramax® and Hansen® gearboxes for North and South America markets. The facility has in-house machining, milling, gear cutting, grinding, surface treatment, testing, assembly, and quality control facilities.

Asia Pacific Facilities

APAC Operations

Our assembly and service centres are strategically located in the Asia Pacific region and places us in closer touch with our customers. All our facilities are capable of providing fast delivery and engineering support.

• Singapore (HQ)



Our Asia Pacific HQ in Singapore provides marketing, engineering and inventory support to all subsidiaries and customers in the region. With the largest assembly and stock centre in the region, customer's requirements are attended to quickly. We also serve emerging markets countries such as Bangladesh, Mongolia, Laos, Myanmar, Sri Lanka, Cambodia and Pakistan.

• Thailand - Chonburi



This assembly plant in Chonburi serves our customers in the Kingdom with quick delivery of products, spare parts as well as repair and engineering services. With extensive Sales offices locations throughout Thailand in Bangkok, Khonkaen, Lampang, Songkhla, Surat Thani and Nakornratchasima, our Salespersons are at closer reach to our customers.

• Australia - Sydney



Established after the merger with Hansen Australia to form Sumitomo (SHI) Hansen Australia, this facility has served engineering, service, stock and assembly centre operations at Glendenning. Together with the new service centre at Mackay and satellite sales offices at Brisbane, Hunter Valley, Melbourne and Perth with dedication to serve our customers needs across the country.

• Indonesia - Cikarang



With established sales, engineering and service centres in this facility, stocks, assembly and after sales service support capabilities are able to cater to the growing market in the country. Including Java, we have sales offices at North Sumatra, East Kalimantan and Central Kalimantan to bring our services closer to every region in Indonesia.

• Malaysia - Shah Alam



A 33,000sqft ESC facility near Kuala Lumpur, this facility is equipped to stock and assemble from small gearmotors to large gearboxes to serve our customers in the Electronics, Packaging, POM, Rubber, Material Handling and Mining industries. With sales offices spanning from our assembly centre here in Shah Alam, to sales offices in Johor Bahru, Penang and Sabah, serving wide industries.

• Australia - Mackay



Our newest office addition to the Asia Pacific region, this service centre factory is located in Central Queensland and boasts the ability to overhaul and repair gearbox units back to their original OEM specifications. Alongside with Sydney's operation, both facilities strives to be in service for local customers.

• Philippines - Manila



A fully equipped Cyclo Centre and assembly plant in Manila, with just one sales office in Cebu, serving and catering to the country's needs across various industries. Despite few facilities in the country, our brand stands impressively strong here.

• Vietnam - Ho Chi Minh



Our sales and service facilities in Ho Chi Minh and Hanoi are supported by well-trained engineers for diverse industries including F&B, Cranes & Hoists, Animals & Livestock, Power, Mining, Cement and Material Handling industries.



Scan for our facilities address & contact