

NEW PARAMAX® DIGESTER SERIES**Paramax® YVD065P3DG**

Our new Paramax® Digester Series - YVD065P3DG, is packed with various essential features upgraded and improved to meet existing application demands. This new addition to our YHD series for the POM industry is an excellent choice if you are seeking any of the following benefits.

Full Benefits

- 100% Leak Proof - Drywell, prevents Palm Oil Contamination
- 20% Higher torque than YVD060
- Split housing for easy maintenance
- Long lasting gearbox
- 10 years bearing lifetime*
- SF1:66 at 55kW full load start
- 65% Lubrication oil cost saving
- Lower operating temperature
- Low maintenance cost
- 100% Japan bearings

**100% Leak Proof - Drywell**

0% Palm Oil contamination from digester gearbox

**Long Lasting Operation**

Increased 20% torque with estimated 10 years bearing life at 55kW operation (365 days x 12hrs)*

**55kW Full Load Start**

The highest rated torque (Nm) - SF:1.66 at 55kW in the industry for 4000L-6500L Digester Tank

**Lower Maintenance Cost**

Cooler gearbox, longer oil life with 59L oil savings per oil change, ~USD1700 per gearbox over 10 years!

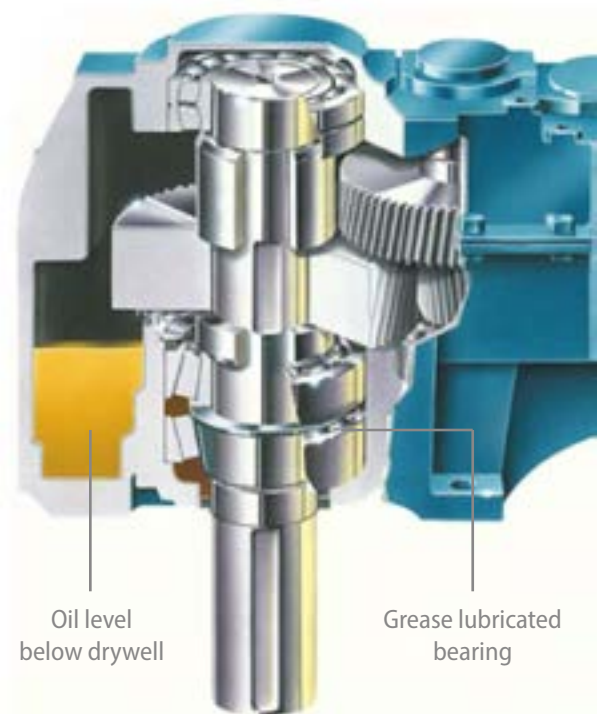

Oil level below drywell

Grease lubricated bearing

Drywell construction

Digester Drive 6000L New

YVD065P3DG-RL-57.328

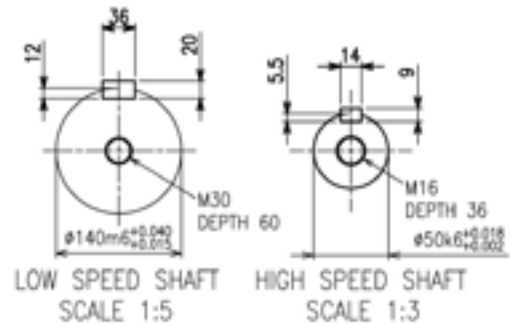
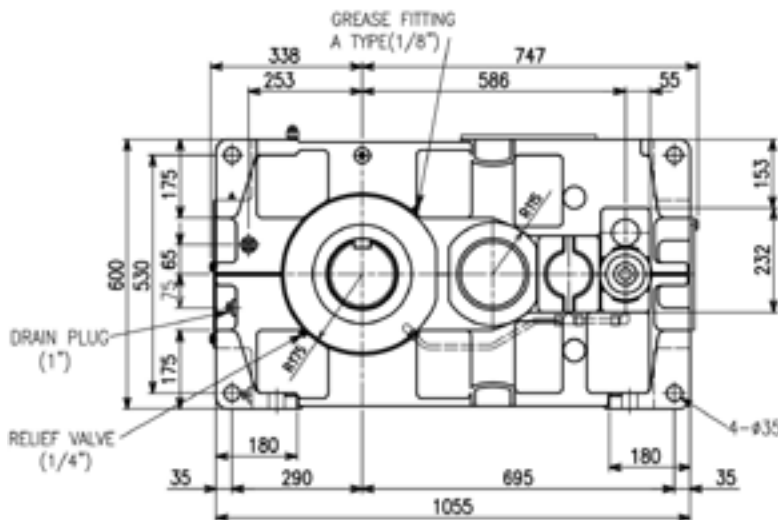
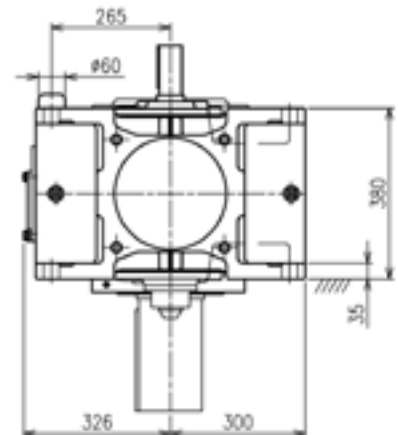
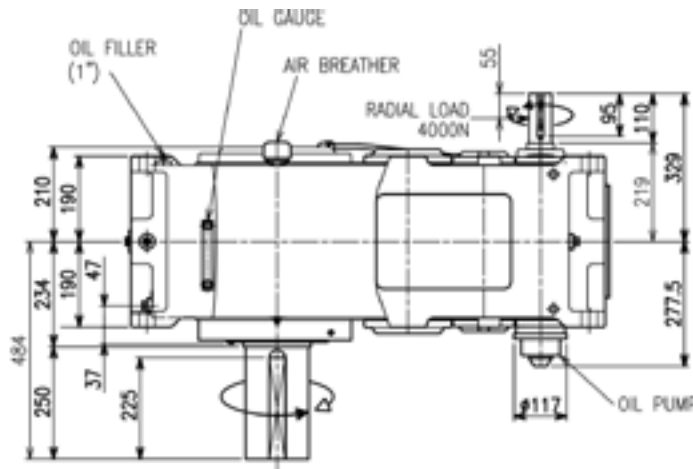

DIGESTER DRIVE 6000L REDUCER SPECIFICATIONS

Model	Ratio	Torque Rating <i>Nm</i>	Input Speed <i>rpm</i>	Output Speed <i>rpm</i>	Power Rating <i>kW</i>	Output Shaft dia <i>mm</i>	Input Shaft dia <i>mm</i>	Weight (approx.) <i>kg</i>	Oil Qty (Approx) <i>/</i>
YVD065P3DG-RL-56	56.206	38,000	1500	26.7	106	140	50	815	35

Lubrication System
Lubricant

Oil
ISO VG460 AGMA 7EP